

## SSV60108MS

### Manual 6000# 108" Aluminum Cradle with Stainless Steel Fasteners

Your SHORESTATION Aluminum Boat Lift is designed to give years of dependable service. Following the enclosed instructions will insure you that your lift is properly assembled.

#### SSV60108MS

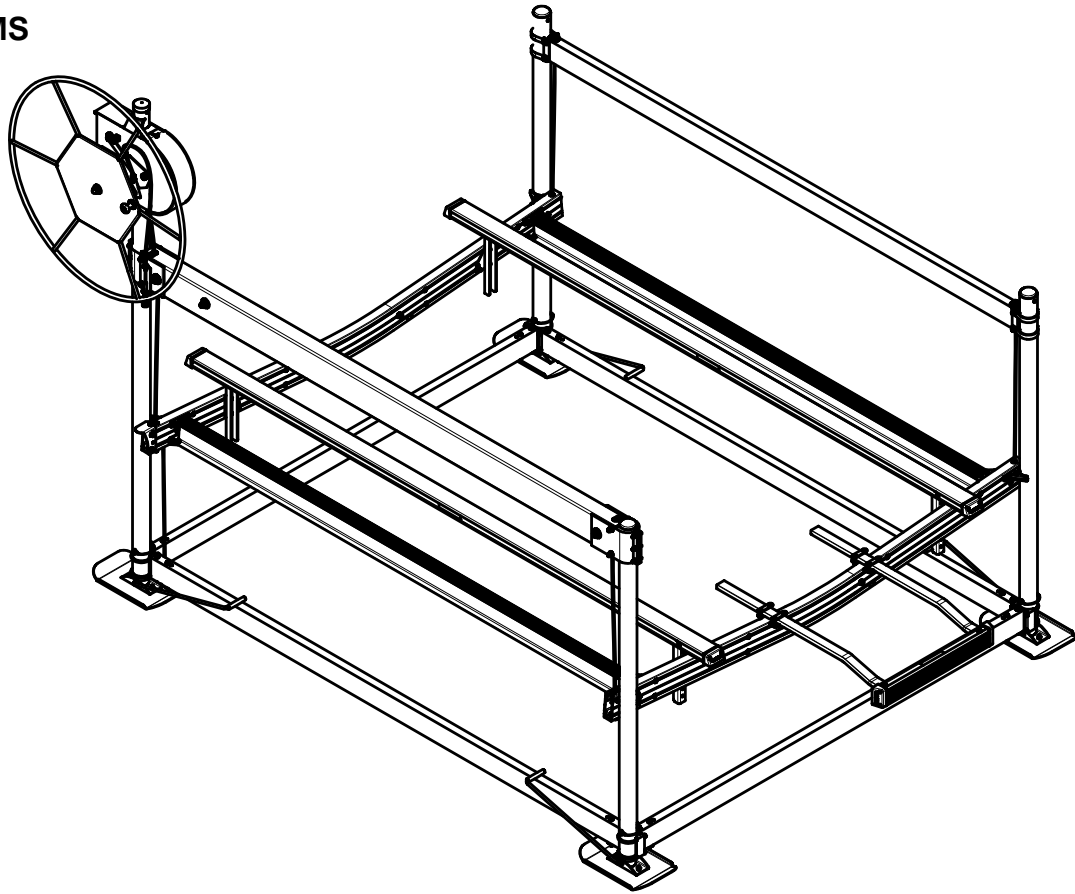

#### SSV60108MS STANDARD LIFT

68261	Lower Frame Bundle 50/60108
70225	Platform Bundle Alum 50/60M&E
7035701	Wheel Big Lift ShoreStation SS
7036501	Winch Assy Hoist 60108/120 SS
70366	Winch Tube Bundle V60108/120 SS
70362	Leg Bundle SSV60108/60120SS
70412	Lit Packet SSV60108MS
70364	Hdwe Box SSV60108/120MS/E
HA0086	Bunk Poly 4000H/6000M/E Alum
HA0087	Motor Stop Bundle 5.75 Alum V

**ATTENTION:** This Boat Lift uses stainless steel fasteners. ALWAYS apply anti-seize to fastener threads before assembly to prevent galling or seizing.

For more detailed information regarding the Installation, Transporting, Operation, Safety, Maintenance, and additional accessories available for your lift see your SHORESTATION Operators Manual.

## Table of Contents

You and Your ShoreStation.....	3	Assembly Instructions.....	21 Thru 37
Using Your Lift.....	3 & 4	Tools Required.....	21
Detail Drawings & BOM.....	5 thru 19	Pads.....	21
Base Pad.....	6	Pad-Leg-Lift Arm.....	22
Lift Arm.....	6	Lower Frame.....	23 Thru 25
Leg-Winch.....	7	Platform.....	26 Thru 28
Leg-1, 2, 3.....	8	Spacer Tube.....	28 & 29
Lower Frame.....	9	Level Cable Connections.....	30
Platform.....	10	Winch Tube.....	30
Spacer Tube.....	11	Winch.....	31
Cable Connections.....	11	Wheel Stop Assy & Brkt.....	32
Winch Tube.....	12 & 13	Winch & Lift Cable Connect...33	
Winch Attachments.....	14	Bunks.....	34
Bunk Attachment & Assy.....	15 & 16	Motor Stop.....	35
Motor Stop.....	17	Leg Caps.....	36
Lift Wheel.....	18	Adjustments & Operators Info.....	37 Thru 42
Winch Assembly.....	19 & 20		

## YOU AND YOUR SHORESTATION

We at ShoreStation would like to thank you for purchasing one of our boat lifts.

Our goal is your complete satisfaction. That is why we recommend reading this manual in its entirety. A better understanding of your lift's features and adjustments will make your boating experience more pleasurable.

It is important that you maintain and store your boat lift and accessories properly to ensure that it continues to provide the dependable performance year after year.

**IMPORTANT:** Read this manual carefully with special attention directed toward all WARNING, CAUTION, and IMPORTANT information.

## USING YOUR LIFT

### Basic Lift Operating Tips and Guidelines

**IMPORTANT: Before using your Shore Station lift, read this Owner's Manual for detailed operation instructions and safety information.**

Here are some basic guidelines to follow:

**Know the maximum capacity of your lift.**

It is important not to exceed the maximum load capacity of your lift. Overloading could cause mechanical failure and serious personal injury. Be especially cautious to remove the drain plug on boats which are stored on lifts without canopies. The weight of the boat could greatly increase during a rainstorm and exceed the lift's load capacity.

**Never board a boat while it is raised on the lift**

Always lower the lift platform before boarding the boat so the boat is almost floating free from the platform, but is still stabilized by the platform. This will aid in the user's ability to load while not placing excess weight on the lift.

**Do NOT let Children Play on or around the Lift**

Children should not be allowed to play under or around the lift.

**Use Caution During Maintenance and Repairs**

Always remove the boat from the lift and fully lower the platform before any maintenance and repairs are performed. Only remove the safety shields after the platform is fully lowered. Never reach through the wheel and manipulate any of the winch mechanisms when the platform is raised.

**Remove the drain plug from the boat before leaving for any length of time, especially if the lift does not have a canopy cover.** Accumulation of water in the boat from a rainstorm may increase the weight of your boat passed the capacity of the lift.

**Properly Positioning the Boat on the Lift**

The boat should be positioned on the lift so that there is an equal amount of weight on each platform. This position will vary from boat to boat because the center of gravity on every boat is different. The equal weight distribution is determined by how far forward or backward the boat is positioned on the lift. Once identified, adjust the motor stop (adjustable on 1500 – 9,000 lb. aluminum lifts) or front end boat stop (USED ON INBOARDS) so it will stop the boat in this position in future use.

**Positioning an Inboard Boat on the Lift**

When placing an inboard boat on the lift, it is necessary to install a front-end boat stop on your lift. This option will protect your drive shaft and prop from being bent when the platform is raised to support the boat. The boat must be positioned rearward far enough so the bunks are supporting the boat before the drive shaft contacts the cross member as the platform is raised. A new lift installation for an inboard should NOT have the motor stop installed. If an existing lift is going to be used for an inboard, the motor stop should be removed before placing the boat on the lift.

**Platform Height Positioning**

The height that the platform should be positioned when the boat is removed for use is best determined by lowering the lift platform until the boat is about to float above the platform. Once at this point, start the engine and put the unit in reverse. With the engine idling, continue to lower the platform. As the boat breaks free from the platform, the power of the engine in reverse will pull the boat out of the lift. Discontinue lowering the platform at this point. Positioning the platform at this point will allow the platform bunk system to also serve as a centering system guiding your boat into the lift when you return.

Upon returning to the lift, slowly drive your boat into the lift. Doing so will allow the bunk system to center your boat on the lift platform. Continue to power into the lift until the boat is stopped by either the motor stop or front end boat stop installed on your lift.

**Level Installation**

The lift must be installed so it is setting level both front-to-rear as well as side to side. Doing so will allow the lift to operate without binding as the platform is raised and lowered.

**For Added Safety and Security**

Always lock your lift when it is unattended for any period of time. Set the wheel lock in the “locked” position on lifts equipped with mechanical winches. A padlock can be placed around the spoke on the big wheel and then through the wheel lock for added security. This protects both you and your boating equipment.

The diagram below and the line art drawings on the following pages are there to give you information on where parts are used and if needed the part numbers you will need if replacement parts are needed.

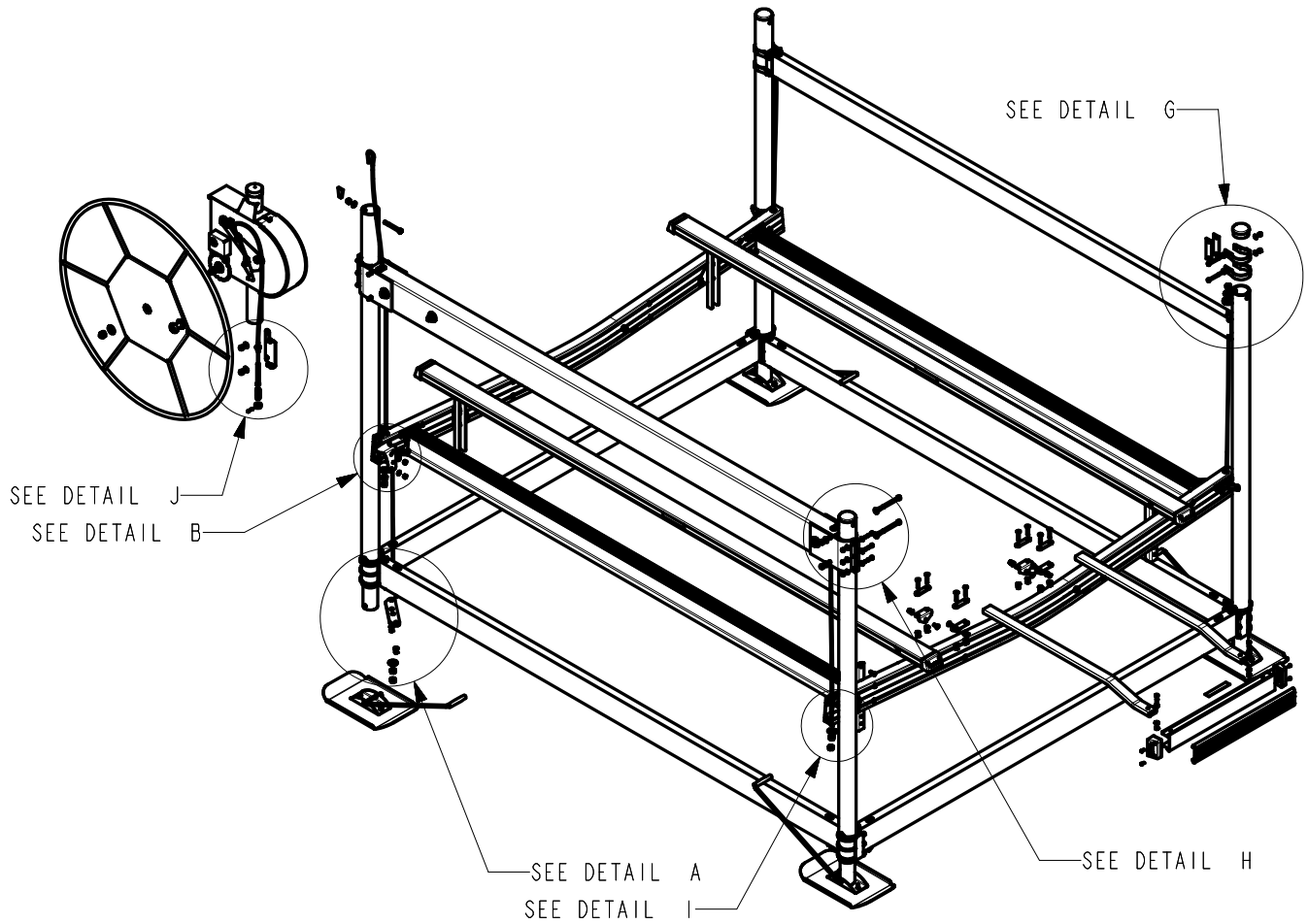

ITEM	PART #	DESCRIPTION	QTY	NOTE
1	0250130	CARR 3/8-16 X 1 GR5	2	
2	1450099	HEX LOCKNUT 3/8 SS W/NYLON INSER	2	
3	A103	ALUM BASE PAD	1	
4	A104	ALUM BASE PAD CHANNEL CLAMP	1	

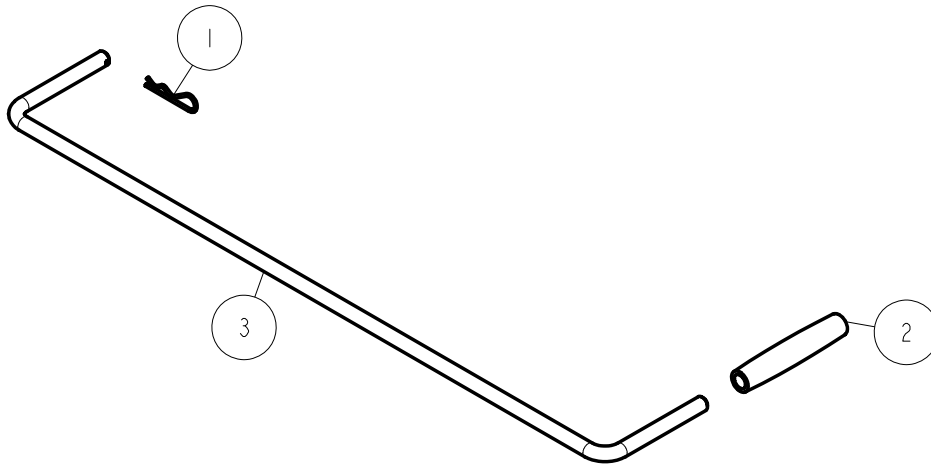
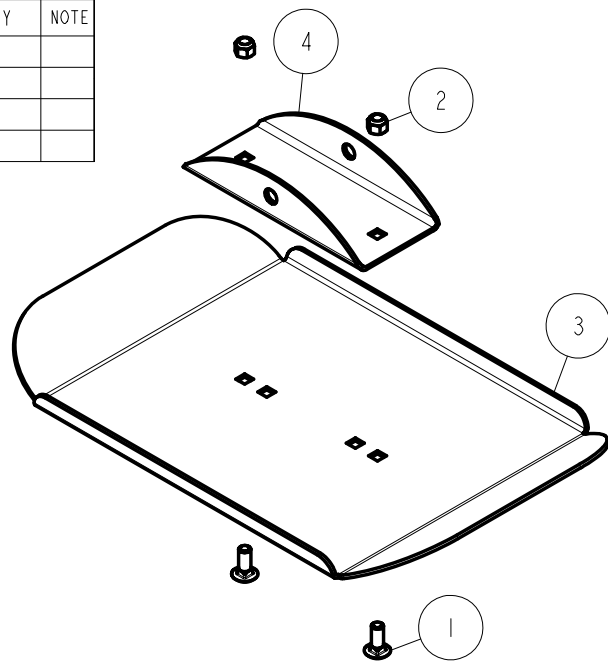

ITEM	PART #	DESCRIPTION	QTY	NOTE
1	1550300	HAIR PIN COTTER #207 3/32 SS	1	
2	3510014	GRIP BLACK 1/2 ID X 4 1/2 LONG	1	
3	A141	LEG LIFT ROD(BOAT LIFT)	1	

## Standard Winch Tube Leg Assemblies

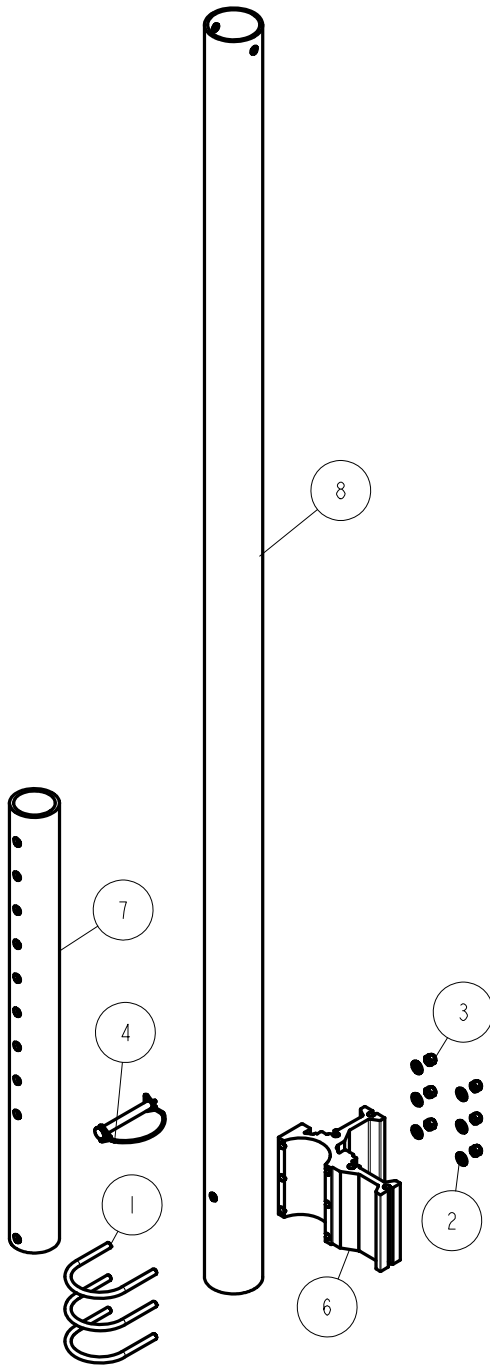

ITEM	PART #	DESCRIPTION	QTY	NOTE
1	0350097	RUB 3/8-16 X 3 7/8 X 4 5/8 SS	3	
2	1350095	WASHER USS FLAT 3/8 STAINLESS	6	
3	1450099	HEX LOCKNUT 3/8 SS W/NYLON INSER	6	
4	1540306	PIN STAINLESS STEEL W/RETAINER	1	
5	4811319	DECAL ADJ GAUGE 30 X 1 1/4	1	
6	A302	LOWER CORNER BLOCK 6IN FRAME	1	
7	A315	ADJUSTABLE LEG 30D X 2 1/2IDX32	1	
8	A355	WINCH POST 3 1/2"OD X 92"	1	

## Standard Leg Assemblies

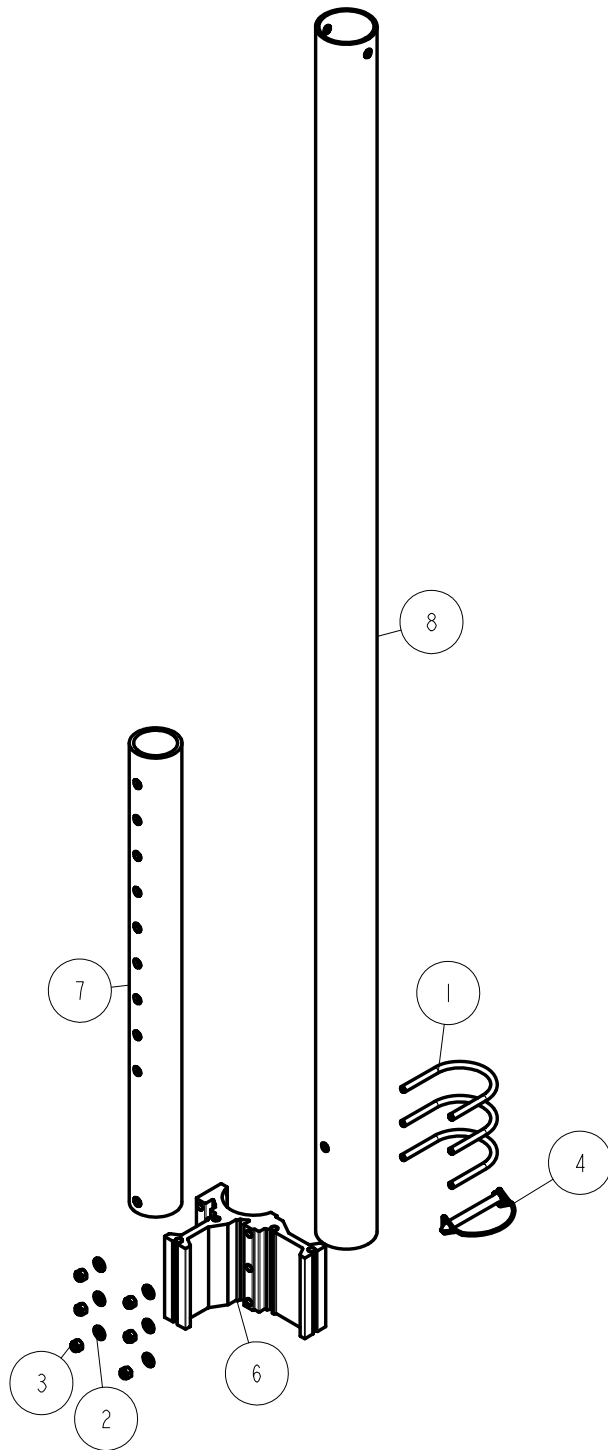

ITEM	PART #	DESCRIPTION	QTY	NOTE
1	0350097	RUB 3/8-16 X 3 7/8 X 4 5/8 SS	3	
2	1350095	WASHER USS FLAT 3/8 STAINLESS	6	
3	1450099	HEX LOCKNUT 3/8 SS W/NYLON INSER	6	
4	1540306	PIN STAINLESS STEEL W/RETAINER	1	
5	4811312	DECAL CLAMP ARROW ALUM HOIST	1	
6	A302	LOWER CORNER BLOCK 6IN FRAME	1	
7	A315	ADJUSTABLE LEG 30D X 2 1/21DX32	1	
8	A354	GUIDE POST 3 1/2"OD X 84"	1	

# Lower Frame Assembly

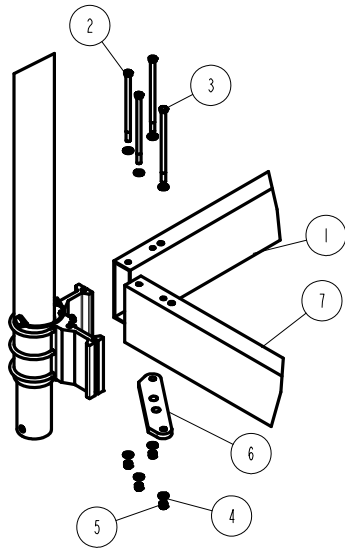
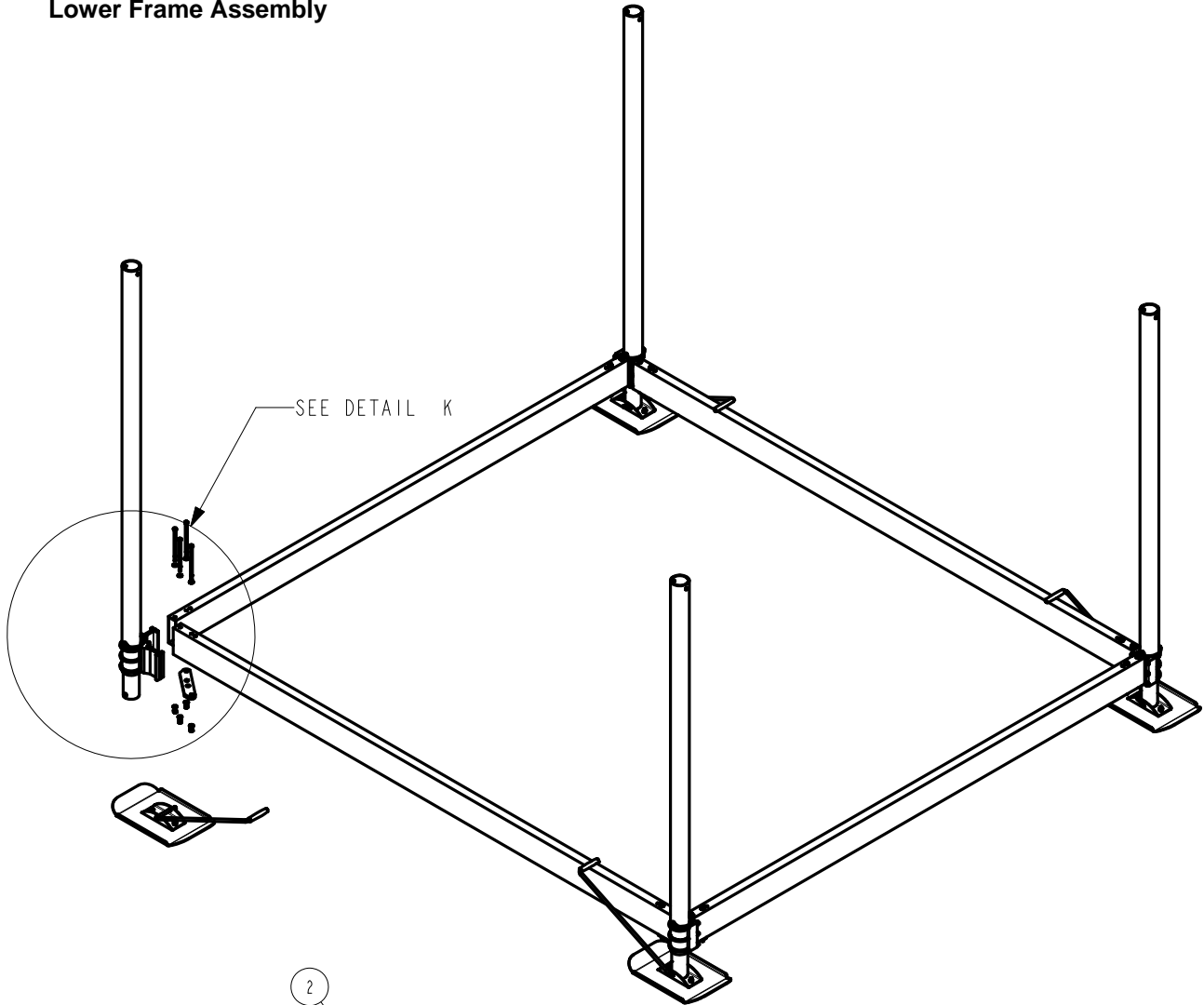

DETAIL K  
SCALE 0.070

ITEM	PART #	DESCRIPTION	QTY	NOTE
1	62689	LOWER FRAME TUBE 6 X 2 X 119IN	2	
2	0150070	HH 3/8-16 X 7 CS GR5-STAINLESS	12	
3	0150071	HH 3/8-16 X 7 1/2 CS GR5-STAINLESS	4	
4	1350095	WASHER USS FLAT 3/8 STAINLESS	32	
5	1450099	HEX LOCKNUT 3/8 SS W/NYLON INSER	16	
6	A126	BOTTOM CORNER CABLE BRKT	2	
7	A352	SIDEFAME 131IN V50120 AND V60132	2	

# Aluminum Platform Assembly

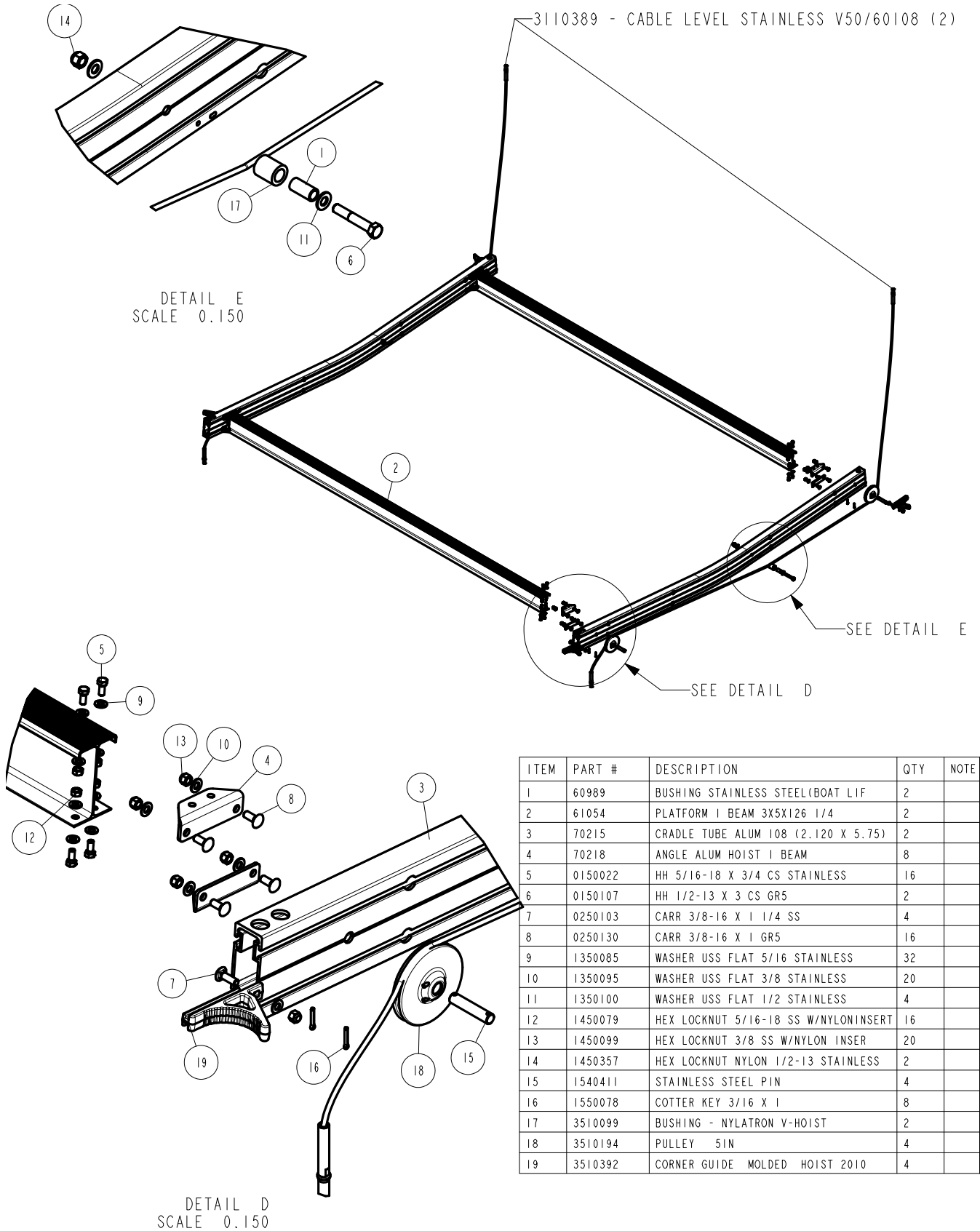

ITEM	PART #	DESCRIPTION	QTY	NOTE
1	60989	BUSHING STAINLESS STEEL(BOAT LIF	2	
2	61054	PLATFORM I BEAM 3X5X126 1/4	2	
3	70215	CRADLE TUBE ALUM 108 (2.120 X 5.75)	2	
4	70218	ANGLE ALUM HOIST I BEAM	8	
5	0150022	HH 5/16-18 X 3/4 CS STAINLESS	16	
6	0150107	HH 1/2-13 X 3 CS GR5	2	
7	0250103	CARR 3/8-16 X 1 1/4 SS	4	
8	0250130	CARR 3/8-16 X 1 GR5	16	
9	1350085	WASHER USS FLAT 5/16 STAINLESS	32	
10	1350095	WASHER USS FLAT 3/8 STAINLESS	20	
11	1350100	WASHER USS FLAT 1/2 STAINLESS	4	
12	1450079	HEX LOCKNUT 5/16-18 SS W/NYLONINSERT	16	
13	1450099	HEX LOCKNUT 3/8 SS W/NYLON INSER	20	
14	1450357	HEX LOCKNUT NYLON 1/2-13 STAINLESS	2	
15	1540411	STAINLESS STEEL PIN	4	
16	1550078	COTTER KEY 3/16 X 1	8	
17	3510099	BUSHING - NYLATRON V-HOIST	2	
18	3510194	PULLEY 5IN	4	
19	3510392	CORNER GUIDE MOLDED HOIST 2010	4	

**Bottom Level Cable Mounting Hardware**

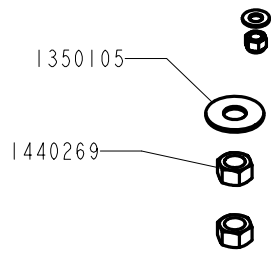
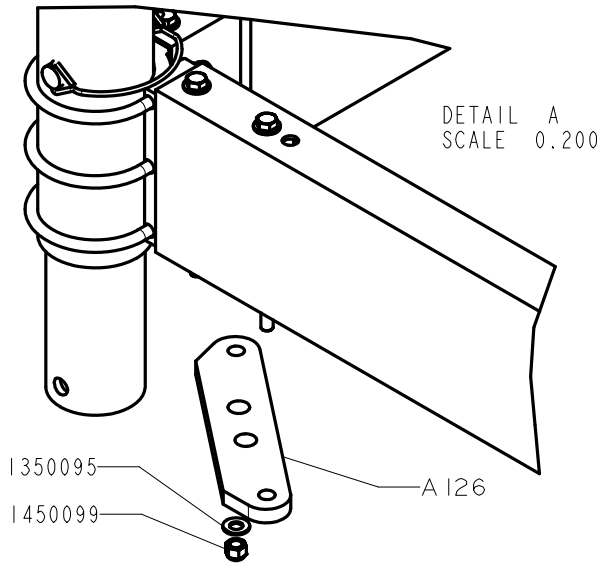

**Brace Tube Mounting/Level Cable Mounting Hardware and Leg Tube Cap**

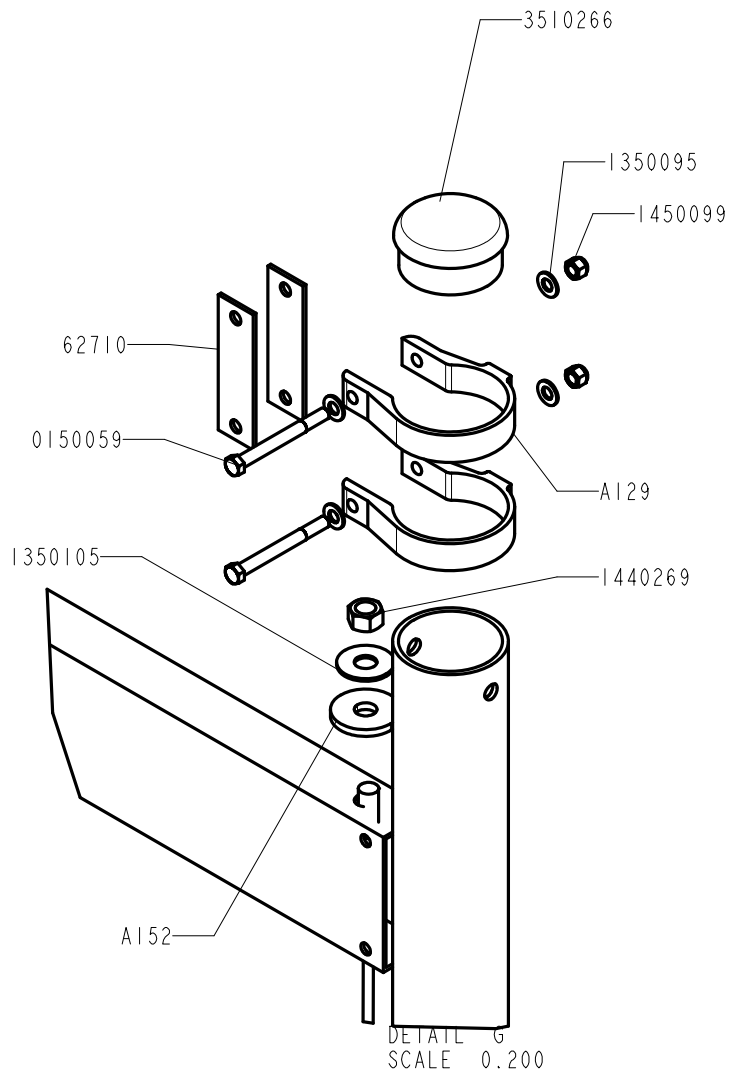

# Winch Tube Assembly

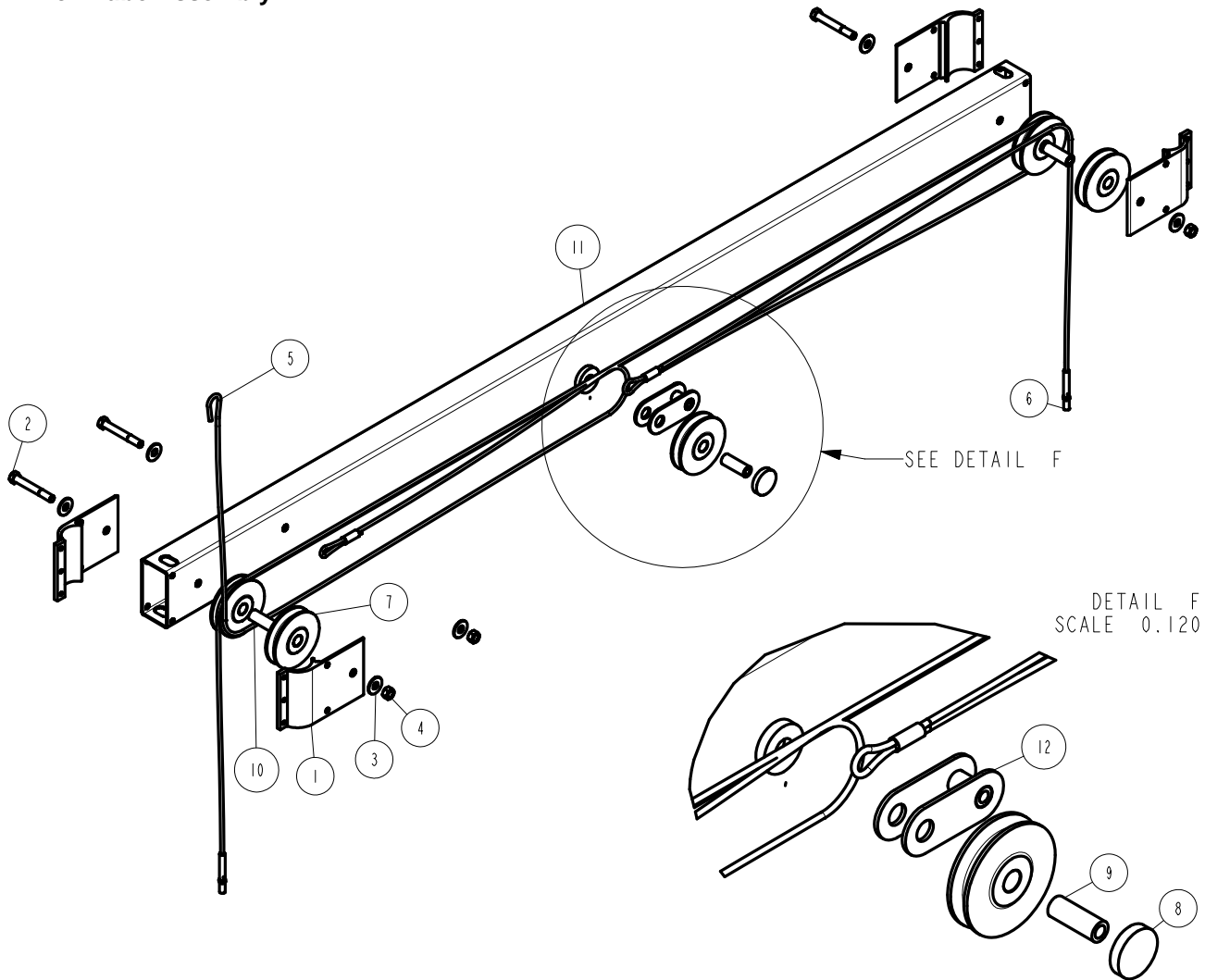

ITEM	PART #	DESCRIPTION	QTY	NOTE
1	62688	WINCH TUBE BRACKET	4	
2	0150288	HH 3/4-10 X 5 1/2 CS STAINLESS	3	
3	1350120	WASHER USS FLAT 3/4 STAINLESS	6	
4	1450309	HEX NUT 3/4-10 STAINLESS	3	
5	3110050	CABLE WINCH V50 V60 AND 5500	1	
6	3110310	CABLE LIFT 50120	1	
7	3510090	6 3/4 DIA. SHEAVE	5	
8	3510091	SNATCH BLOCK GROUND 3IN DIA	2	
9	3610156	STAINLESS STEEL BUSHING - 3 3/8	1	
10	3610158	STAINLESS STEEL BUSHING	2	
11	A356	WINCH TUBE 4 X 7 X 132 55108A	1	
12	A361G	SNATCH BLOCK WMENT	1	

**Winch Tube Mounting Components**

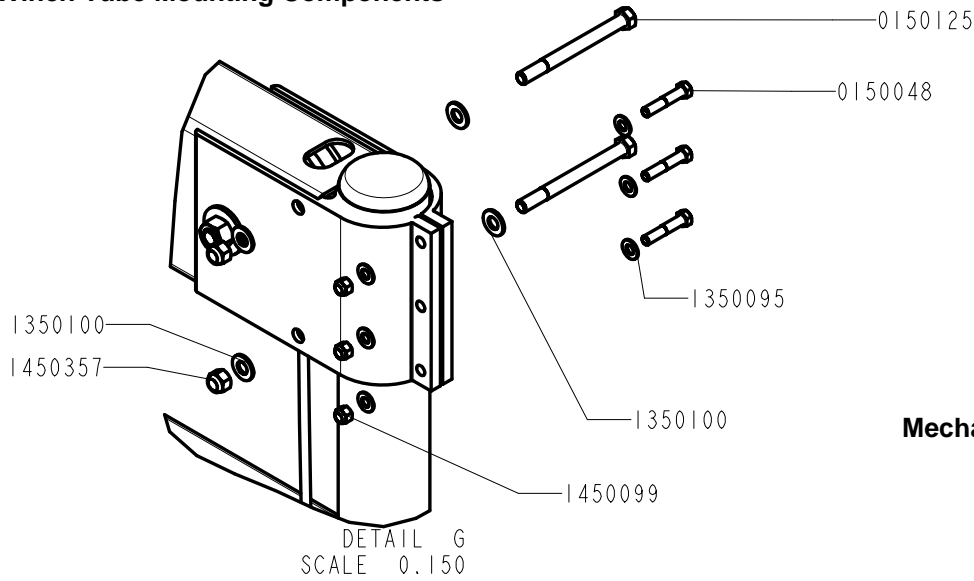

**Mechanical Wheel Stop Mount**

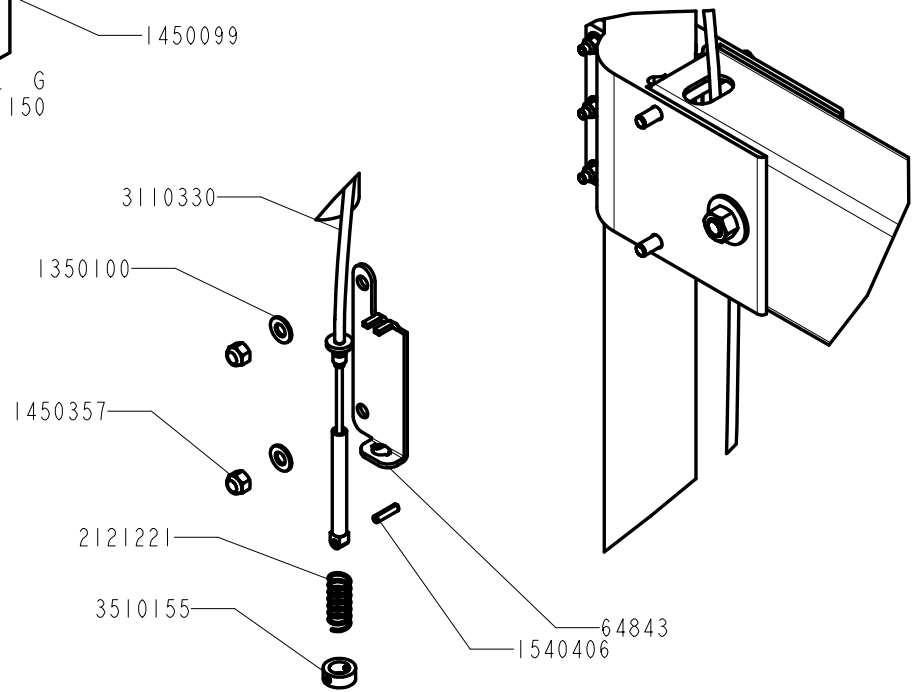

**Lift Cable Mounting Hardware**

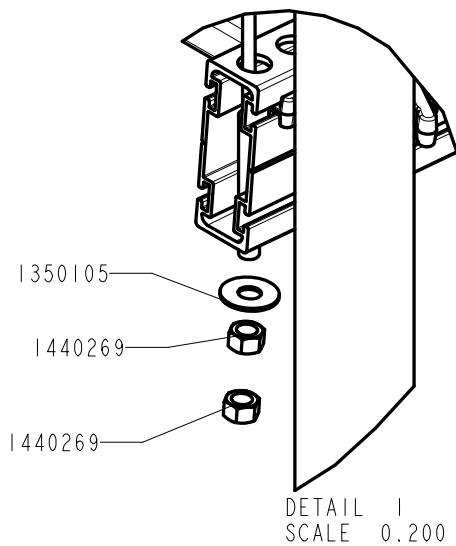

**Winch, Wheel, and Platform Stop Mounting Hardware and Cable Wedge**

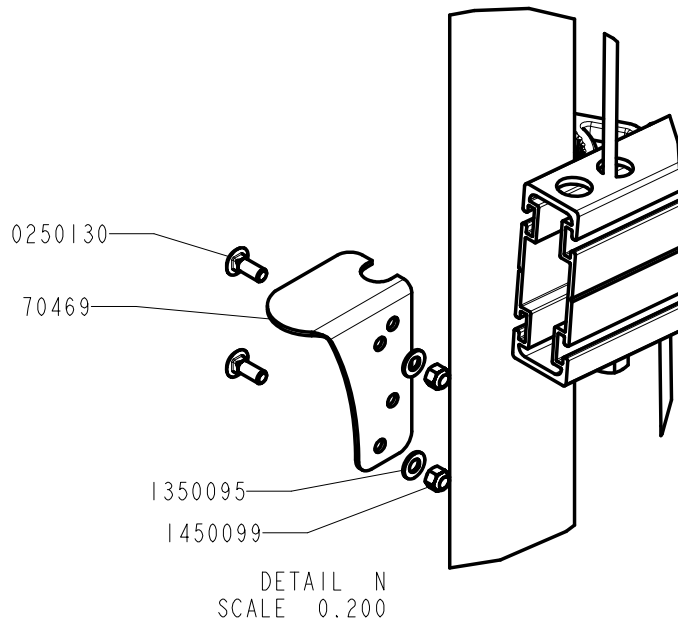
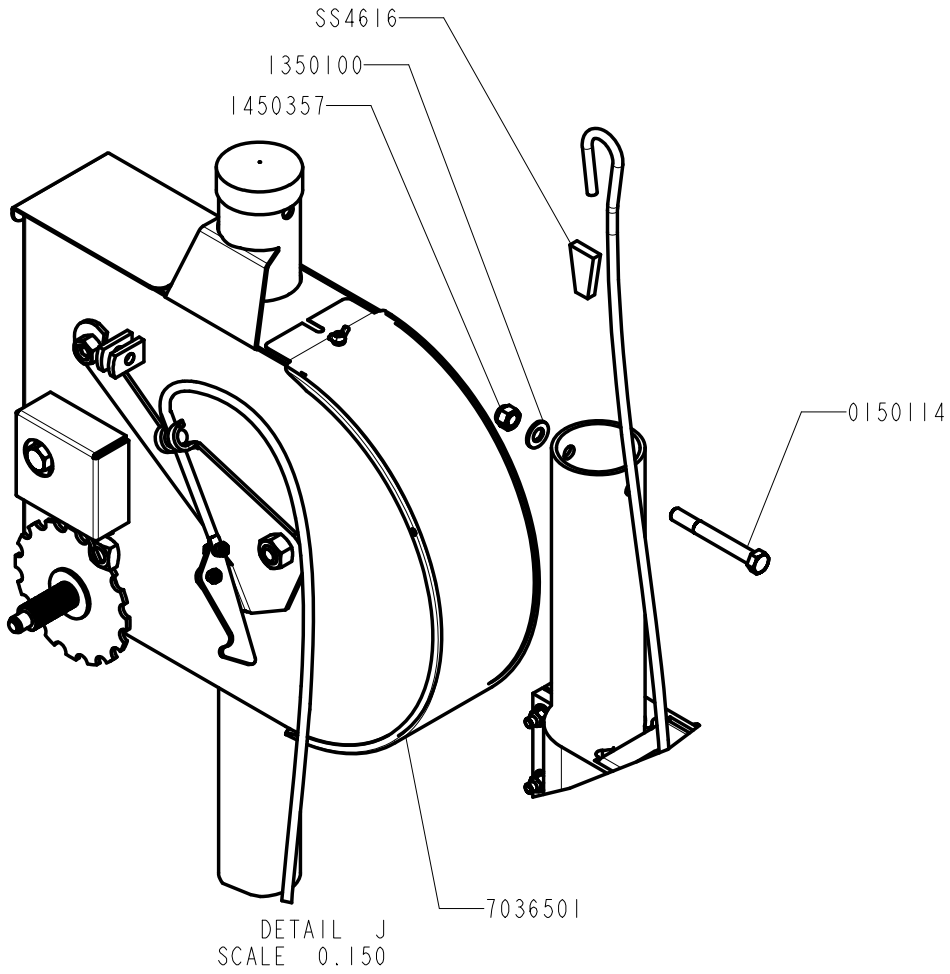

# Bunk Mounting Hardware

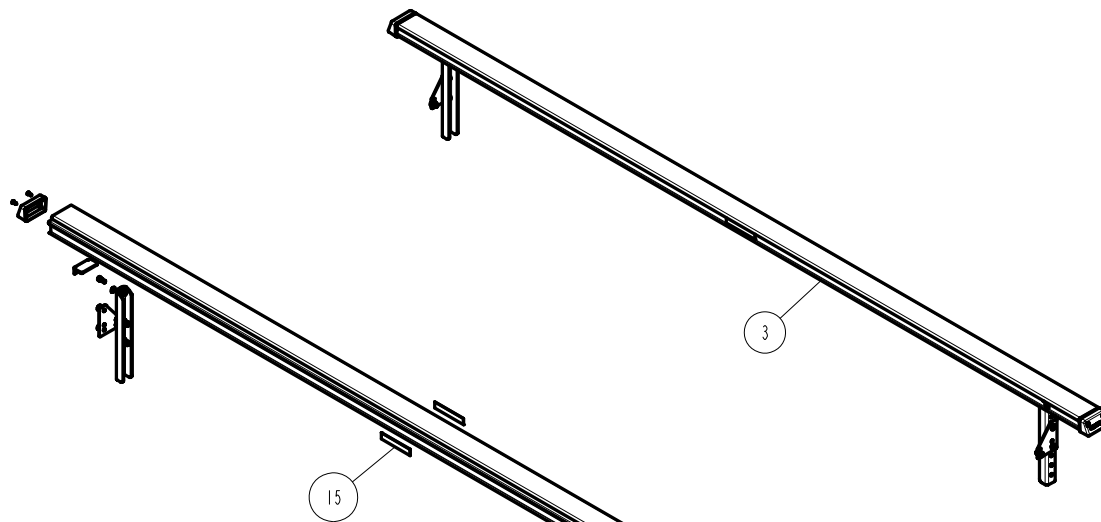

ITEM	PART #	DESCRIPTION	QTY	NOTE
1	69023	BUNK BRACKET	4	
2	69025	EXTRUSION - AL BUNK	2	
3	69030	BUNK ASSY 12FT POLY	2	
4	69050	EXTRUSION - POLY BUNK	2	
5	70221	BUNK BRKT QUICK ADJUST	4	
6	70383	PLATE ALUM HOIST ACCESSORY	4	
7	0150040	HH 3/8-16 X 1 CS STAINLESS	4	
8	0250103	CARR 3/8-16 X 1 1/4 SS	8	
9	0250124	CARR 3/8-16 X 3 1/2 SS GR5	2	
10	0250130	CARR 3/8-16 X 1 GR5	4	
11	0850976	SCREW 1/4-20X3/4 TORX PAN TYPE F SS	8	
12	1350095	WASHER USS FLAT 3/8 STAINLESS	12	
13	1450099	HEX LOCKNUT 3/8 SS W/NYLON INSER	18	
14	3510273	CAP ALUM. BUNK EXTRUSION	4	
15	4850408	DECAL NOT A STEP (SMALL)	4	

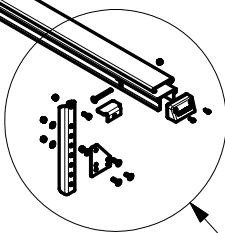

SEE DETAIL F

DETAIL F  
SCALE 0.150

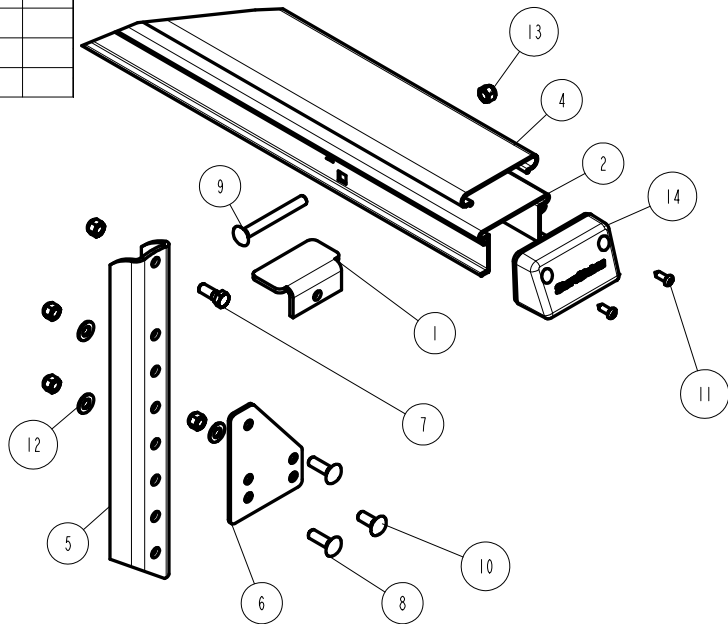

## Motor Stop and Mounting Hardware

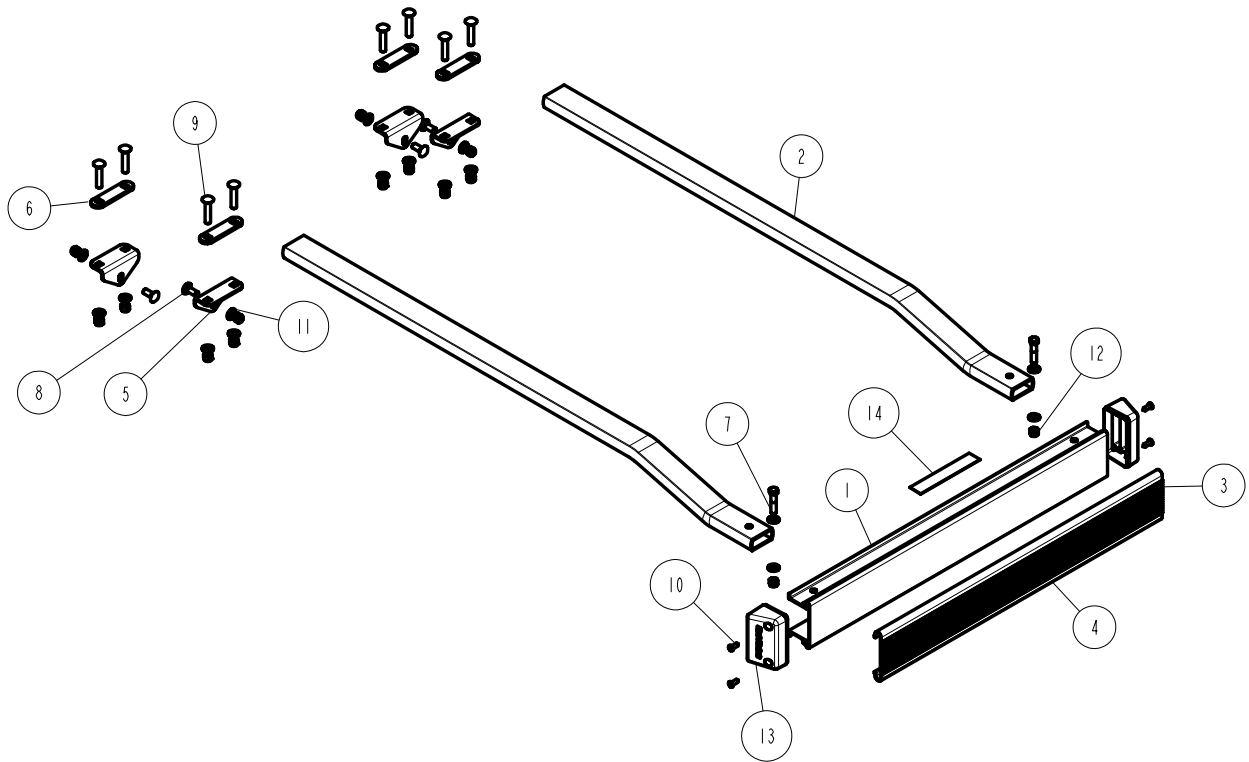

ITEM	PART #	DESCRIPTION	QTY	NOTE
1	69040	EXTRUSION - AL BUNK	1	
2	69042	HOIST MOTOR STOP ARM ALUM.	2	
3	69043	EXTRUSION - POLY BUNK	1	
4	69290	BUNK ASSY 30IN POLY	1	
5	70255	ANGLE MOTOR STOP MOUNT	4	
6	70256	BRACKET - MOTOR STOP TOP	4	
7	0150047	HH 3/8-16 X 1 3/4 CS GR5	2	
8	0250130	CARR 3/8-16 X 1 GR5	4	
9	0250280	CARR 3/8-16 X 2 CS STAINLESS	8	
10	0850976	SCREW 1/4-20X3/4 TORX PAN TYPE F SS	4	
11	1350095	WASHER USS FLAT 3/8 STAINLESS	16	
12	1450099	HEX LOCKNUT 3/8 SS W/NYLON INSER	14	
13	3510273	CAP ALUM. BUNK EXTRUSION	2	
14	4850408	DECAL NOT A STEP (SMALL)	1	

# Winch Assembly

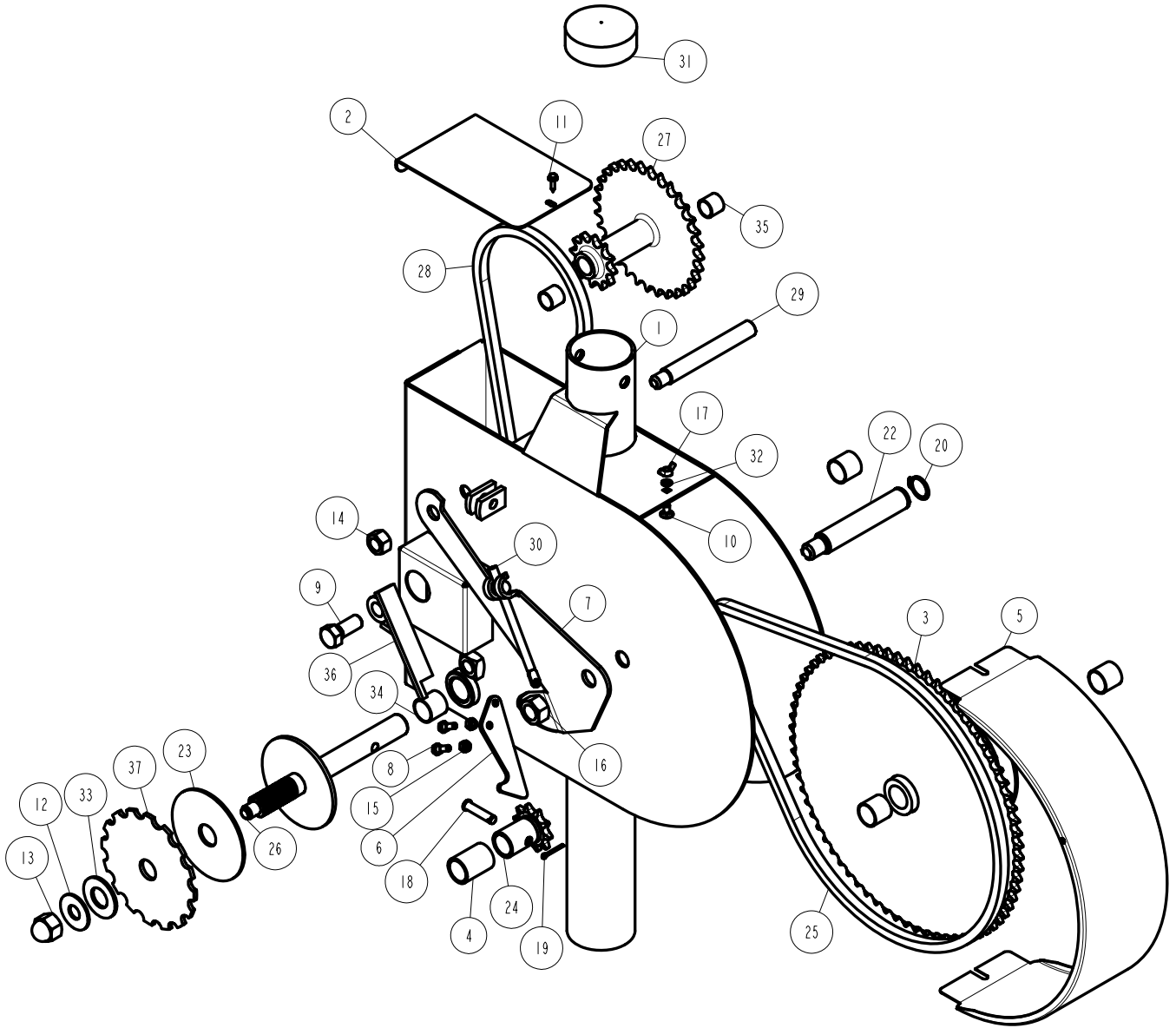

ITEM	PART #	DESCRIPTION	QTY	NOTE
1	62695	WINCH CASE	1	
2	62696	COVER PLATE - 50120/60132	1	
3	62697	CABLE DRUM WMENT BLK	1	
4	62705	DRIVE SHAFT SPACER 50120 60132	1	
5	62706	WINCH CASE COVER 50120 60132	1	
6	64839	WHEEL HOOK - WHEEL STOP	1	
7	64842	WHEEL STOP MTG PLATE-50120, 6013	1	
8	0150020	HH 1/4-20 X 3/4 MS STAINLESS	2	
9	0150181	HH 5/8-11 X 1 1/2 CS STAINLESS	1	
10	0250277	CARR 1/4-20 X 1/2 GR5	2	
11	0810972	SCREW #10 X 3/4 HH SELFTAP STAINLES	1	
12	1350105	WASHER USS FLAT 5/8 STAINLESS	1	
13	1410299	HEX NUT ACORN 5/8-18 BRASS	1	
14	1450028	HEX NUT 5/8-18 SS	1	
15	1450049	HEX NUT 1/4-20 STAINLESS STEEL	2	
16	1450329	HEX NUT 3/4-16 STAINLESS	1	
17	1450364	NUT WING 1/4-20	2	
18	1540215	PIN CLEVIS 3/8 X 1 1/2 IN	1	
19	1550035	COTTER KEY 1/8 X 1 STAINLESS	1	
20	1750025	SNAP RING 1 IN EXTERNAL STAINLESS	1	
21	2500118	LUBRICATION GREASE TUBE	1	
22	3110074	DRUM PIVOT SS55108	1	
23	3110120	CLUTCH PLATE DRIVE SHAFT ASSY	1	
24	3110134	SPROCKET 50B10 PER PRINT	1	
25	3110304	ROLLER CHAIN - #50 N.P. X 82 PITCH	1	
26	3110305	ACME THREAD DRIVE SHAFT	1	
27	3110308	SPROCKET DOUBLE REDUCTION	1	
28	3110311	ROLLER CHAIN - #50 N.P. X 56 PITCH	1	
29	3110312	PIVOT SHAFT DOUBLE REDUCTION	1	
30	3110330	DRIVE TOP LIMIT ASSY	1	
31	3510015	CAP BLACK VINYL 3&1/8 OD WINCH C	1	
32	3510175	PUSH NUT PLASTIC	2	
33	3610080	BUSHING 1 ID X 2 OD X 1/8 OILI	1	
34	3610120	BUSHING 1.1300DX1.016/1.018 ID	4	
35	3610130	BUSHING 7/80DX3/4IDX3/4 BRONZE	2	
-	3910190	VELCRO HOOK PRESSURE SENSITIVE	1	
-	3910191	VELCRO LOOP PRESSURE SENSITIVE	1	
-	4850206	DECAL LUBRICATION TUBE	1	
-	4850224	DECAL CAUTION INSPECT CABLES	1	
-	4850359	DECAL CAUTION ARROW RAISE CLOCKWISE	1	
36	A189	SMALL CLUTCH DOG WMENT	1	
37	SS1122	CLUTCH SPROCKET	1	

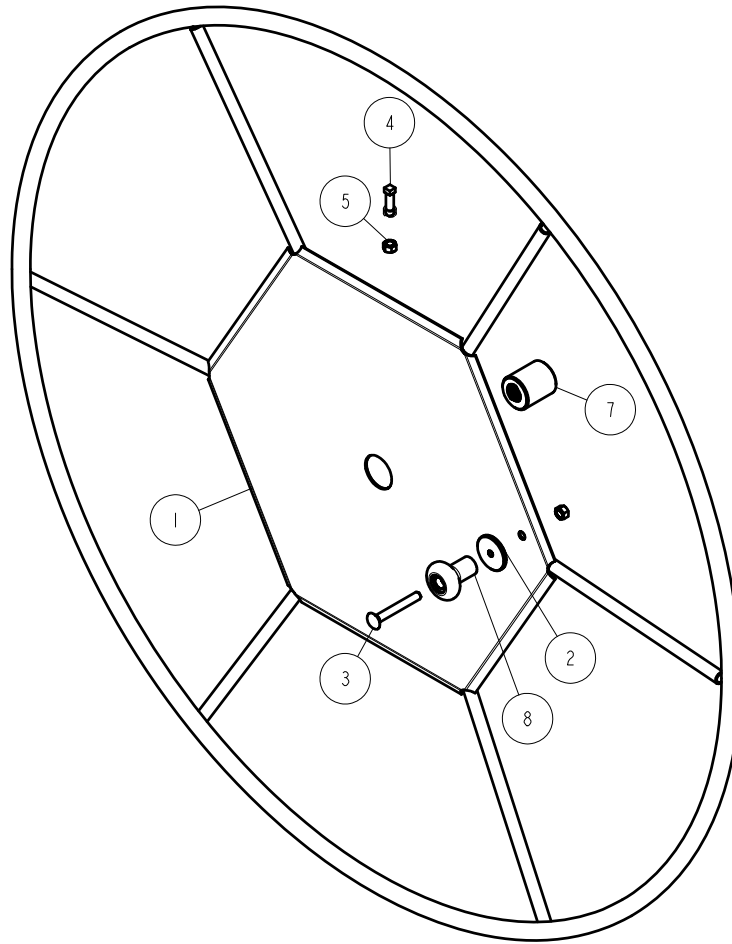

ITEM	PART #	DESCRIPTION	QTY	NOTE
1	63135	WHEEL - LARGE HOIST - WELDED	1	
2	70468	WASHER TAPPED 1 13/16 OD X 7GA ALUM	1	
3	0250128	CARR 3/8-16 X 3 GR5 STAINLESS	1	
4	0610038	SCREW 3/8-16 X 1 1/4 SQ HD SET	1	
5	1410109	HEX NUT 3/8-16	1	
6	1450109	HEX NUT 3/8-16 STAINLESS	1	
7	3110354	ACME NUT LEFT HANDED THREADS	1	
8	3510001	SPINNER KNOB	1	
-	4810700	DECAL BIG WHEEL EMBOSSED	1	
-	4850351	DECAL WARNING UP DOWN SPIN WHEEL	2	

## ASSEMBLY INSTRUCTIONS

The following tools will be needed to assemble your lift. You may use Air, Battery, Electric, or Hand tools to complete the lift assembly.

Sockets or open/box end wrenches; 1/2", 9/16", 3/4" and 15/16"

A soft headed Hammer

Tapered Alignment Punch

**ATTENTION: This Boat Lift uses stainless steel fasteners. ALWAYS apply anti-seize to fastener threads before assembly to prevent galling or seizing.**

The following instructions are written so that it can be assembled by one person.

Remove all hardware items and parts from the hardware box and sort by size. Break all bundles containing the lift parts and sort by item

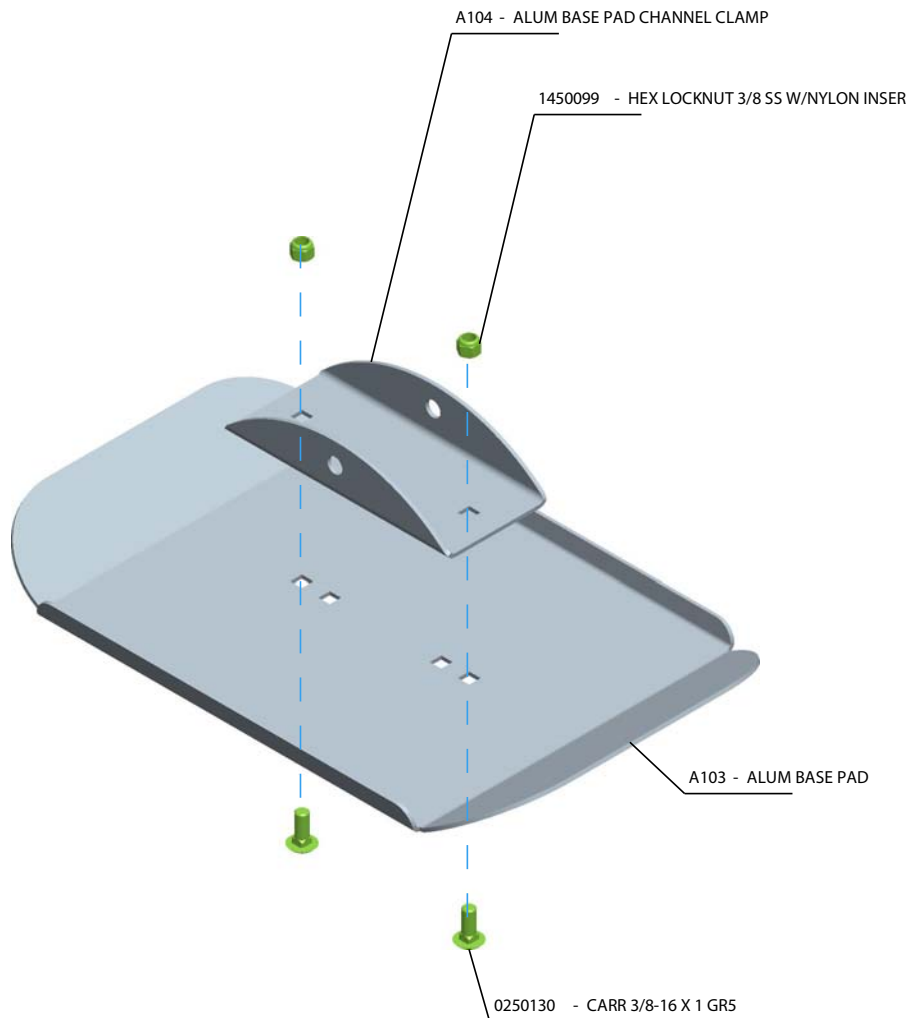

- Attach the base pad clamps to the base pads with 3/8" carriage bolts. Secure with 3/8" nylon lock nuts. Tighten. Repeat on all four base pads.

- Align the holes and attach a base pad assembly to each of the adjustable legs inside the three upright posts and the winch post as shown using the leg adjusting rods and 1/2" hairpin cotter keys.
- Slide a plastic handle grip on the remaining end of the leg adjusting rod

It is recommended that more than one person is going to be needed to assemble this lift. The components to be assembled will be too difficult for one person to handle without some form of assistance.

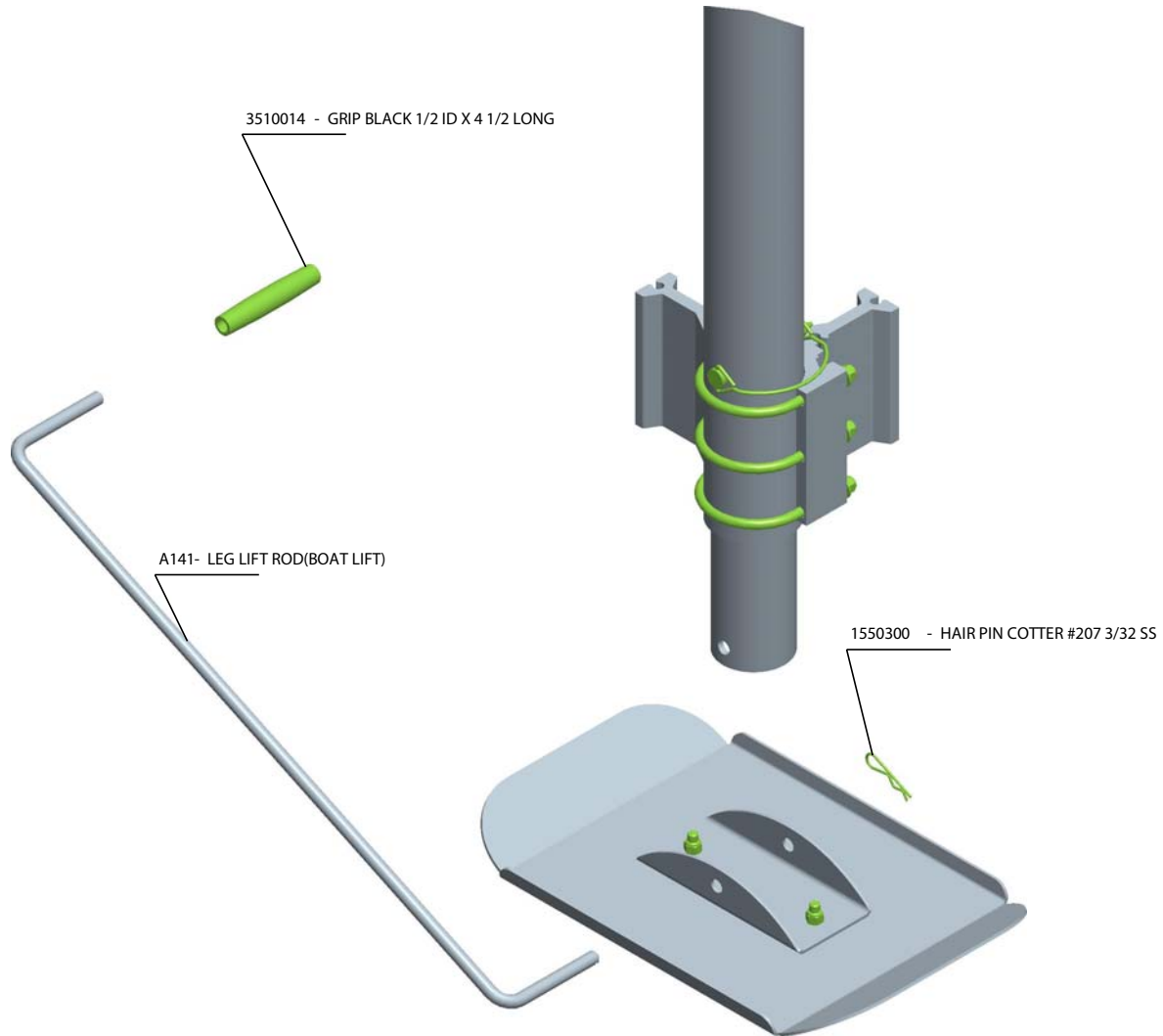

Orientate the lift lower frame components and the upright posts as shown to identify the correct parts when assembling the lift.

- Lay the winch post on its side. Slide the 131" side frame onto the corner block as shown. Secure in place with one 3/8" x 7" stainless steel hex bolt, stainless steel flat washers on both sides of the tube and stainless steel nylon lock nut as shown. Do Not Tighten any of the bolts until instructed later.

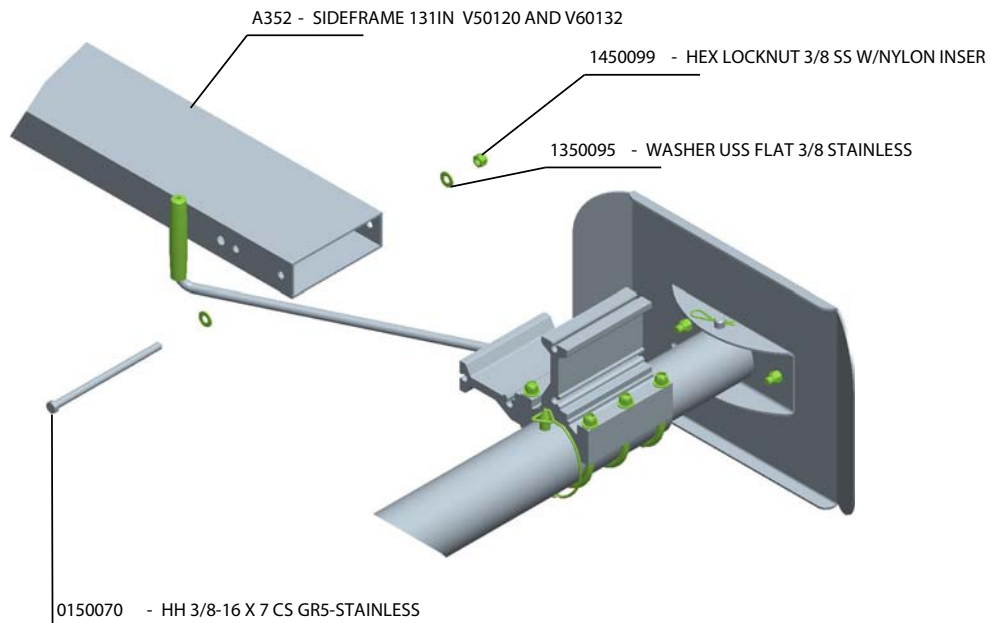
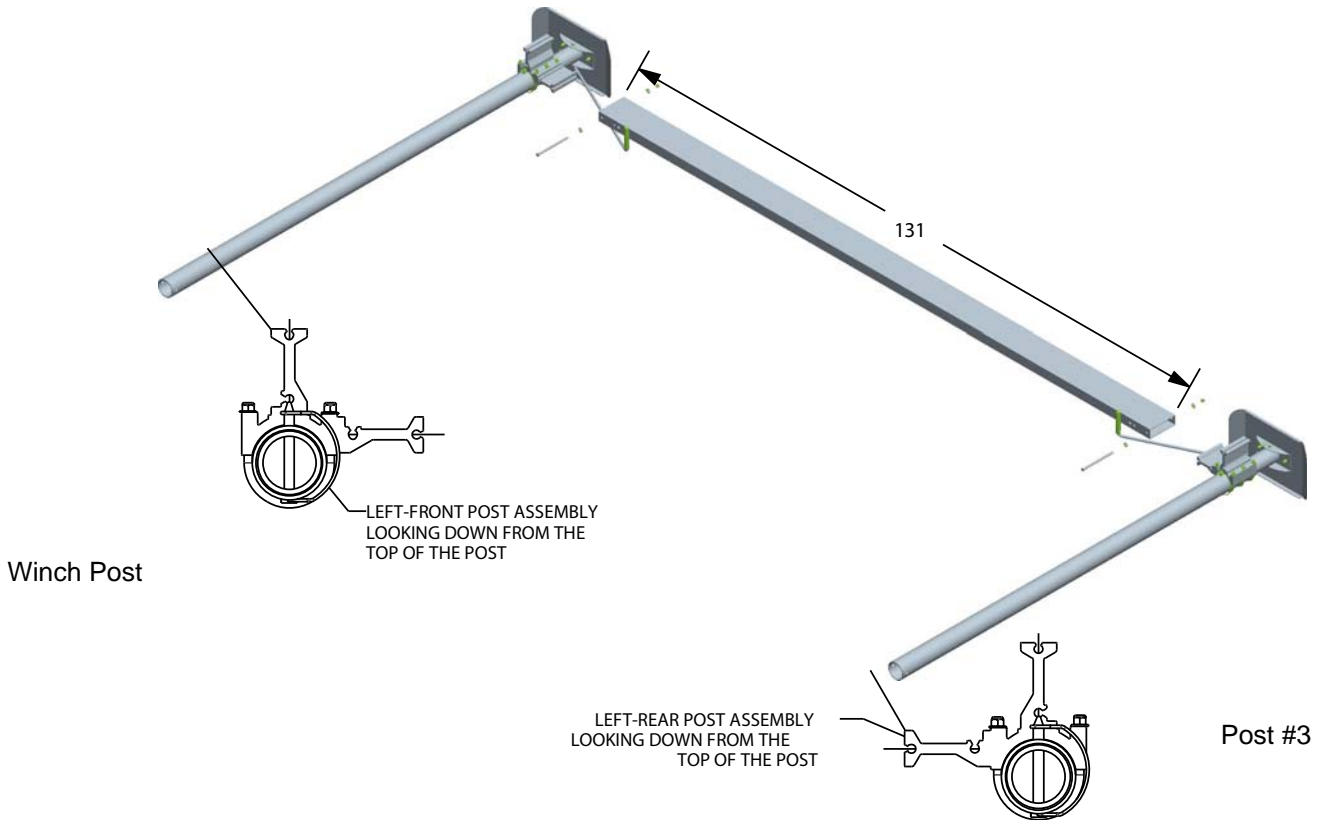

- Slide a 107" cross frame onto the other leg of the corner blocks and secure the same as the side frame.

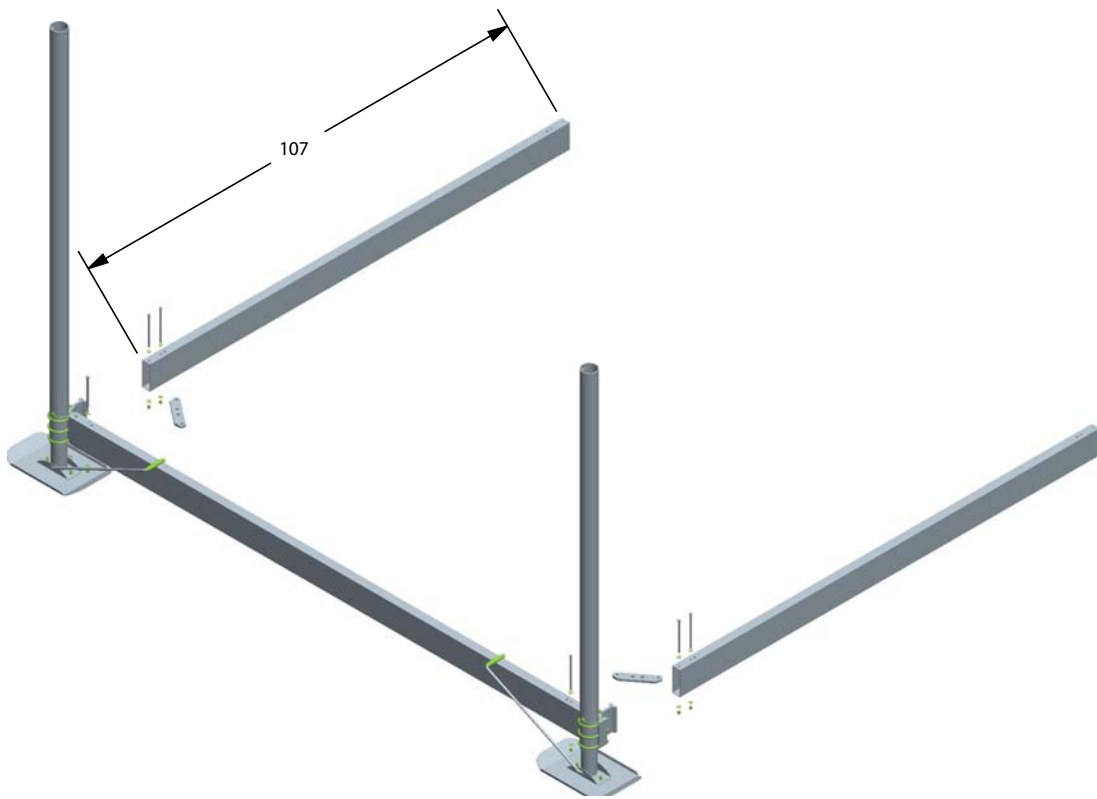

Align the holes in one of the A126 level cable bars with those in the cross frame and side frame. Secure using the 3/8" x 7 1/2" stainless steel hex bolts, stainless steel flat washers both the tube and the level cable bar, and stainless steel nylon lock nuts. At this time it would be recommended to stand the frame up.

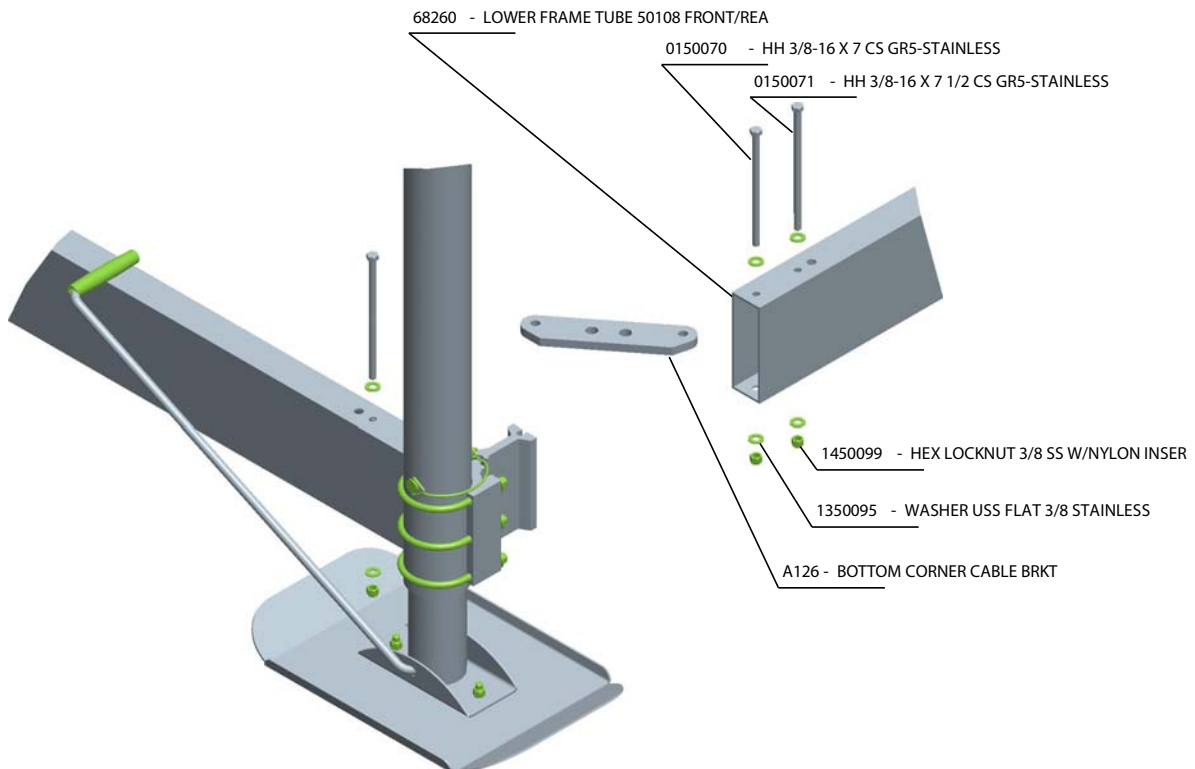

Insert the correct leg of the lower corner block of Post No. 1 into the cross frame attached to the winch post. Slide the remaining side frame onto the other leg. Secure in place using the 3/8" x 7" stainless steel hex bolts, stainless steel flat washers on both sides of the cross tube and secure with stainless steel nylon lock nuts as shown.

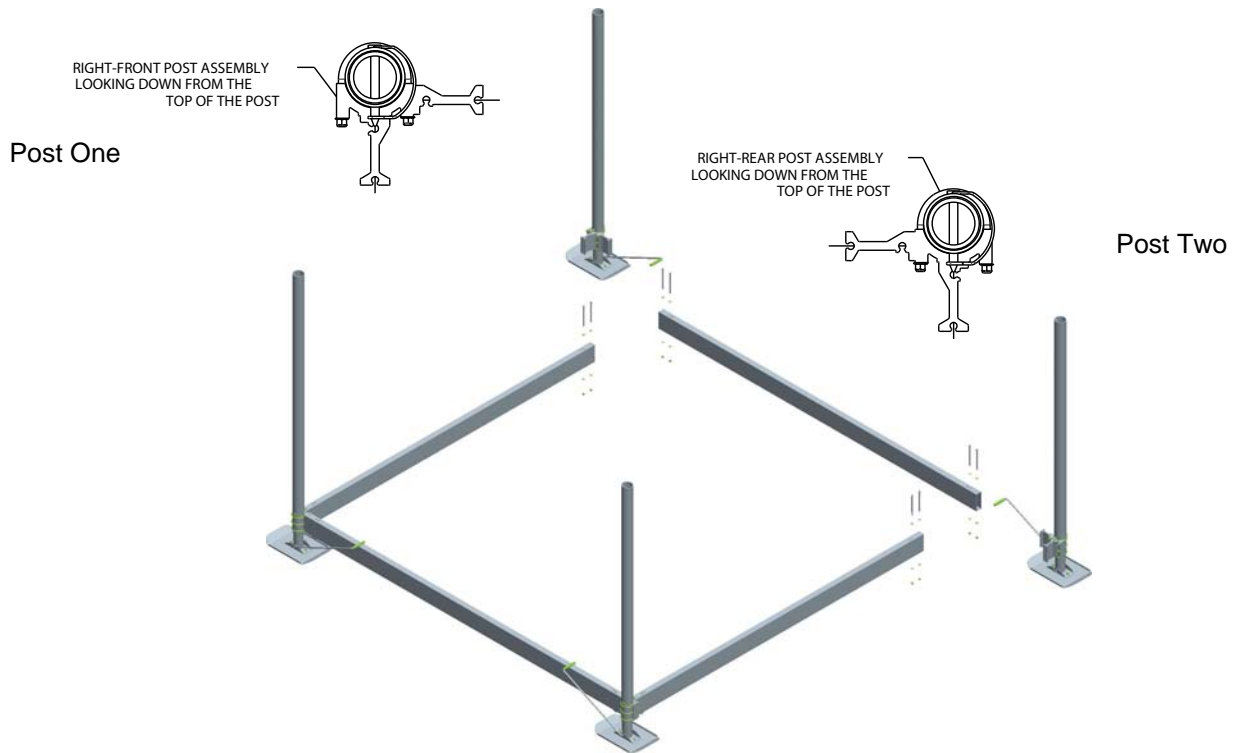

Secure Post No. 2 into place using 3/8" x 7" stainless steel hex bolts, stainless steel flat washers on both sides of the cross tube and the side frame tube and secure with stainless steel nylon lock nuts.

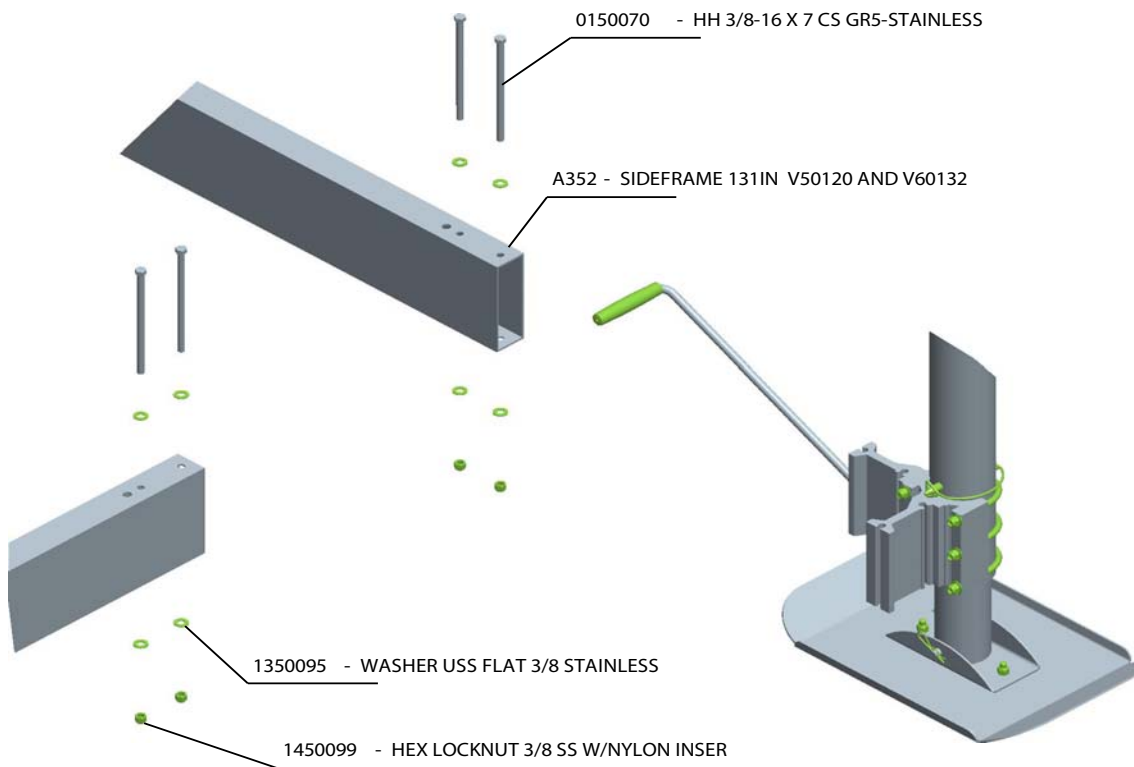

Once all the bolts are installed attaching the upright corner posts to the lower frame, square the frame and tighten all hardware installed at this time.

Shown are the platform components positioned as they will be assembled

Place the two platform assemblies on the side frames as shown so the V in the platform points to the end of the lift and the cable that comes out the bottom of the platform is on the same side frame as the winch.

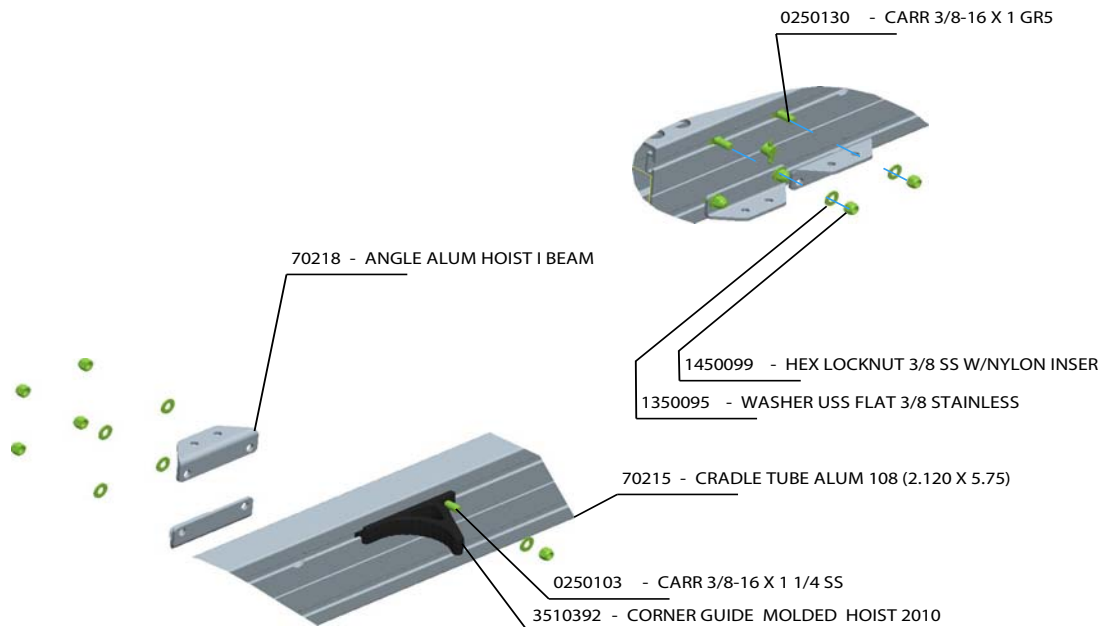
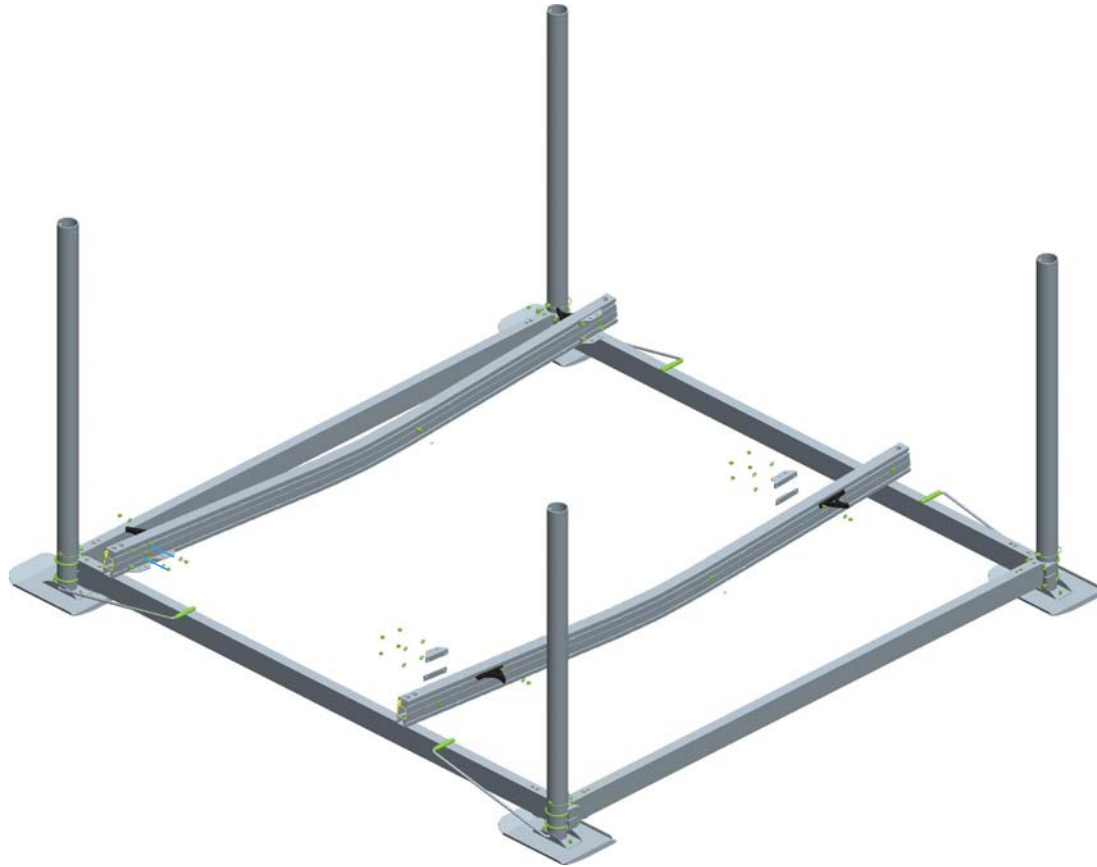

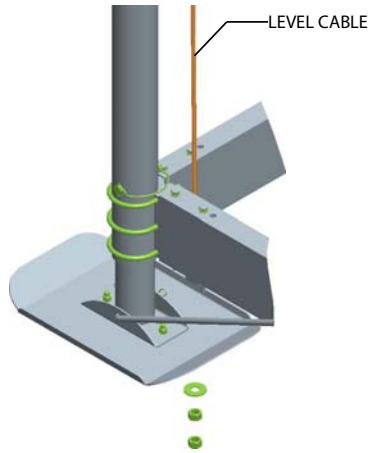

Route the cable coming from over the top of the pulley and out the bottom of the platform to the level cable bar. Insert the cable end through the hole closest to the side frame. Place on a 5/8" flat washer and two 5/8" brass nuts, run the first nut all the way on and then the second. Lock the two nuts together on the threads by placing wrenches on both nuts and then tightening them into each other.

Insert a 3/8" x 1 1/4" stainless steel carriage bolt into the plastic platform guide slide the guide bolt end first into the top slot as shown. Slide this assembly at least 6" into the slot and secure with a stainless steel flat washers and stainless steel nylon lock nut as shown. Do not tighten until instructed.

Do the remaining three plastic platform guides securing as described above.

Place the Angle Alum Hoist I-beam mounting brackets on the opposite sides of the aluminum platform and secure using the hardware shown and position the same for now. Do not tighten until instructed.

- Rotate the platform in its upright position.
- Repeat on the second platform.

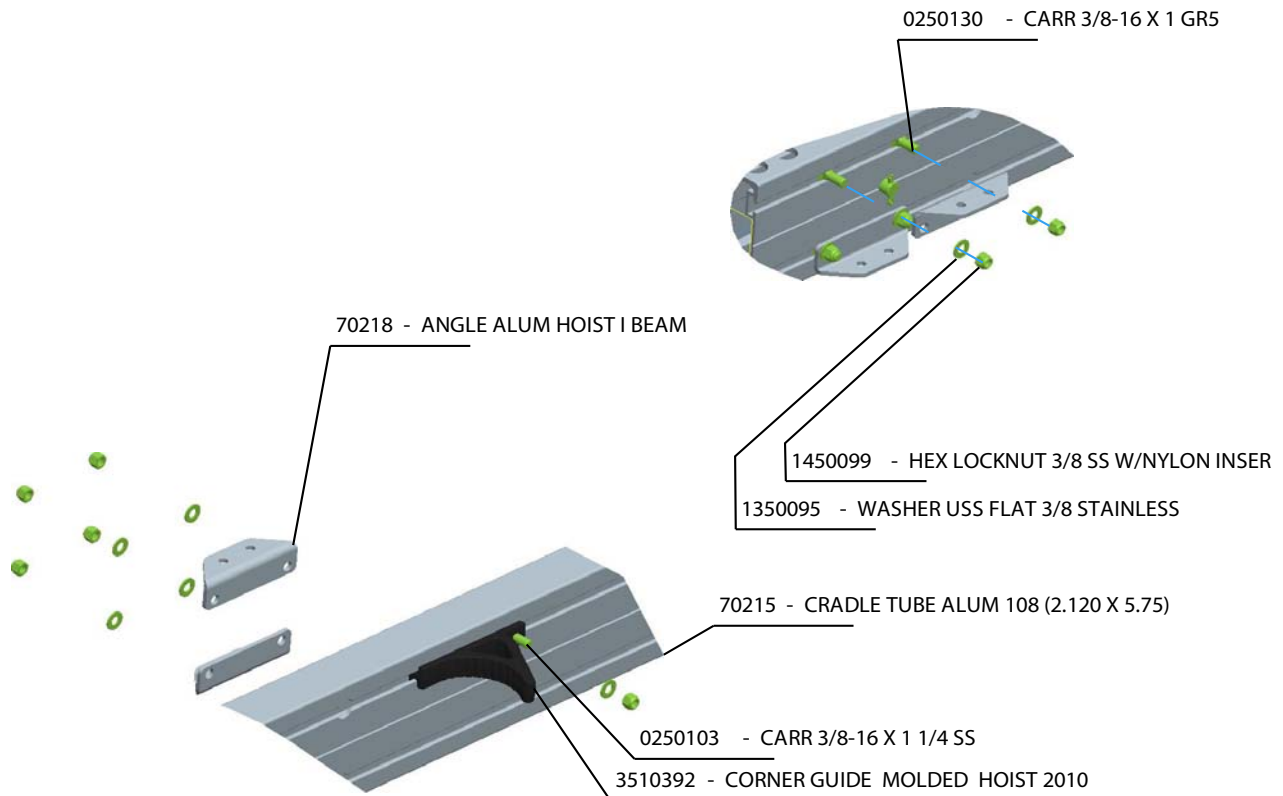
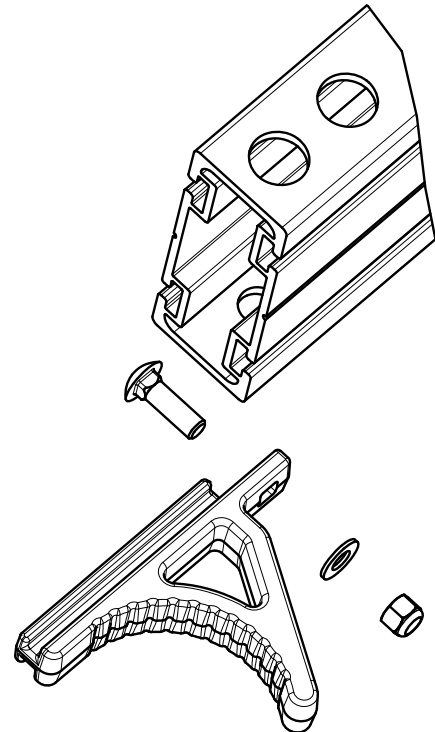

Place the platform I-beams between the two platforms. Align the holes to those in the mounting brackets just attached and secure together using 5/16" x 3/4" stainless steel hex bolts, stainless steel flat washers and stainless steel lock nuts with nylon inserts as shown. Slide the I-beam and mounting brackets on the winch tube side of the hoist to within a 1/2" of the pulley pin and secured to the platforms. Measure the distance from the edge of the bracket to the end of the aluminum V platform and use that dimension to set the brackets and I-beam on the other side.

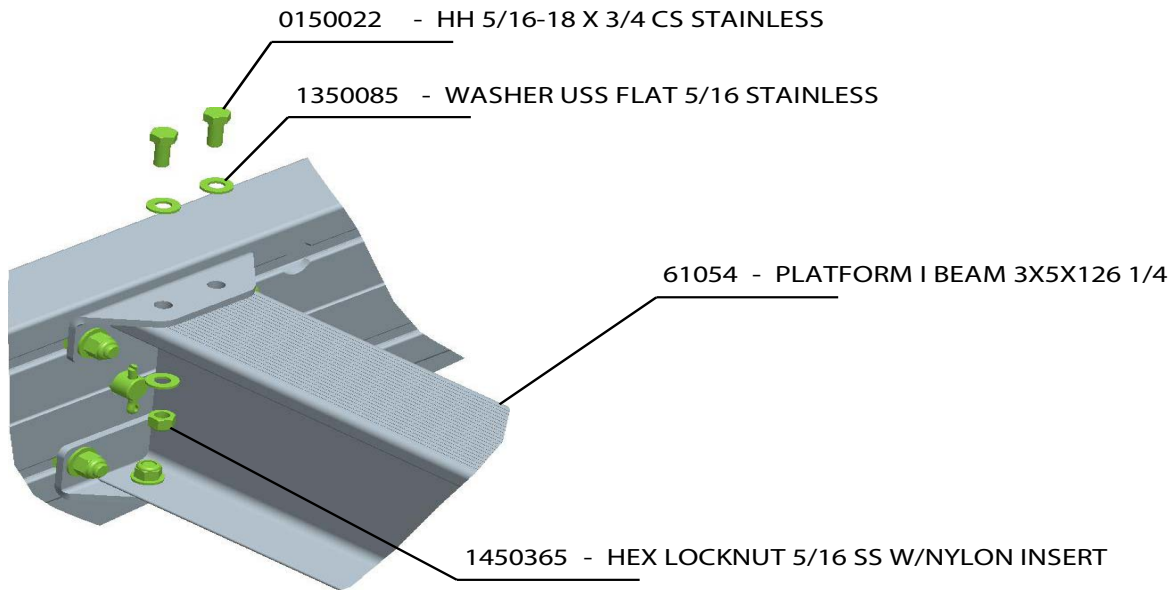

Tighten the bolts after both platform I-beams are in position and all bolts are installed in both the top and bottom of the I-beams.

Center the platform on the lower frame by spacing it evenly between all upright posts. Positioning of the plastic platform guides will take place once the winch is installed and all cables are attached. This will be explained later.

- Place two of the 1" clamps around Post No. 1 and 2 so the top edge of the top clamp is located at the point of the arrow decal. Space them approximately 3" apart.
- Align the holes in the spacer tube, shims, and the clamps and insert the 3/8" x 3 3/4" stainless steel hex bolts and stainless steel flat washer so the heads of the bolts are to the inside of the hoist. Secure with 3/8" stainless steel flat washer and 3/8" stainless steel nylon lock nuts.

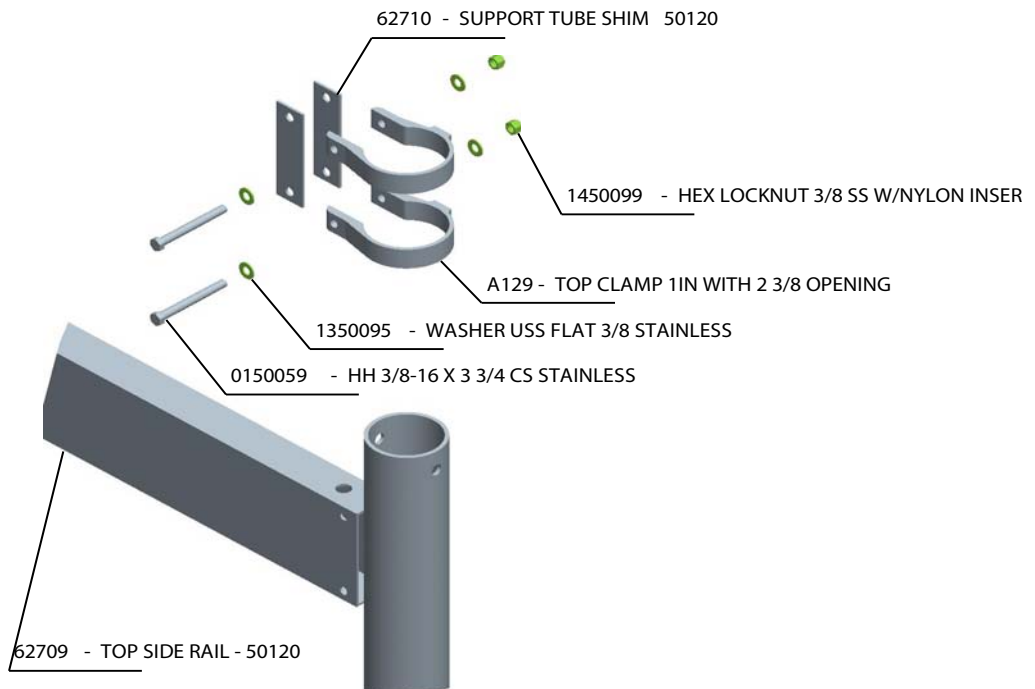
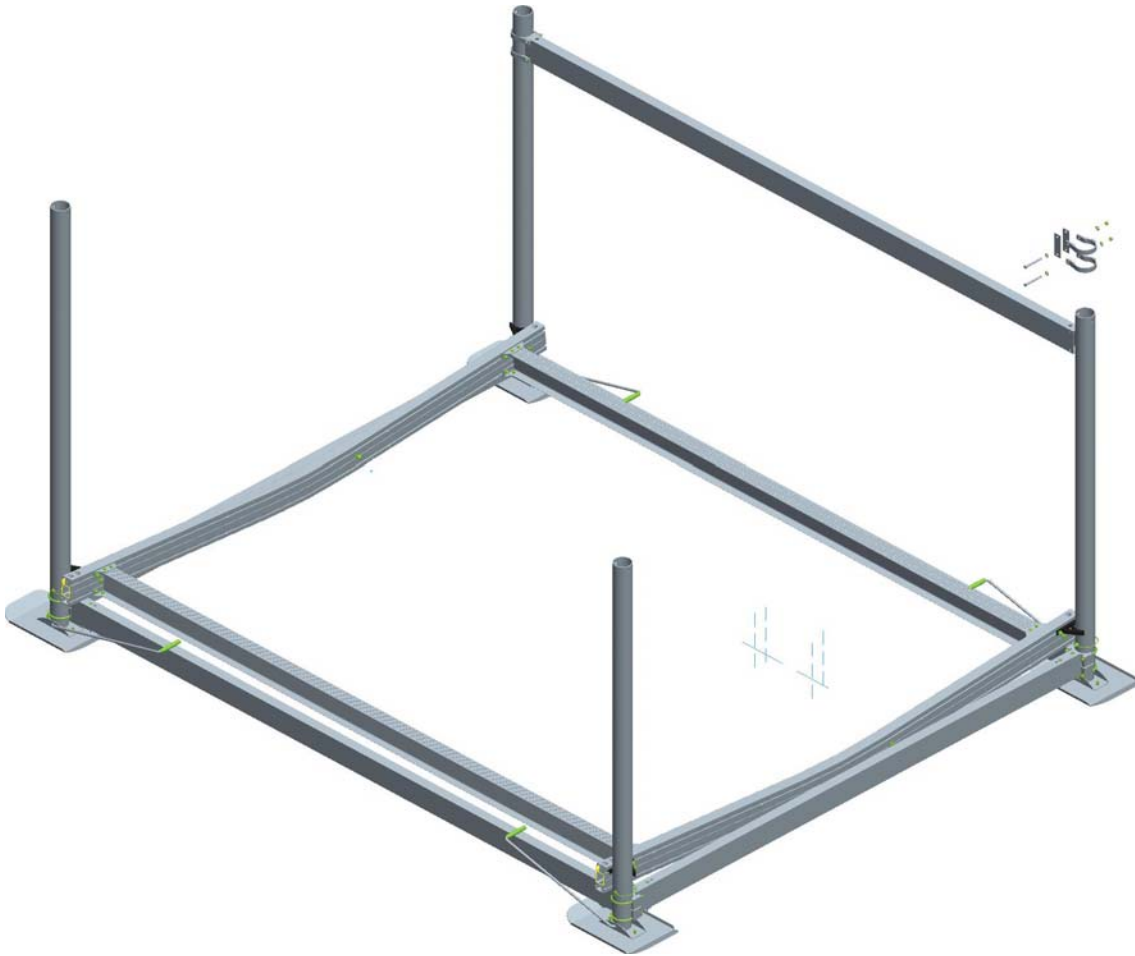

Route the level cable from the bottom of the platform pulley up and parallel with the upright post. Insert the cable

end into the hole in the bottom and out the top of the spacer tube.

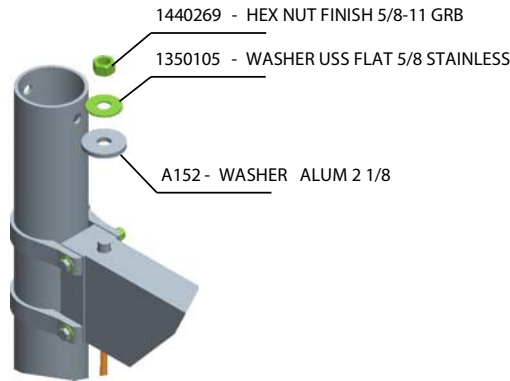

- Secure the cable end by placing on a 2" aluminum washer, 5/8" flat washer and 5/8" brass nut. Thread the nuts on until they bottom on the threads and the slack has been removed from the cable. They may require further adjustment later.
- Repeat on the other platform level cable.

- Locate the arrows on the gauge decals on the winch post and Post No. 3. Position the winch tube so the winch cable will be to the top side and next to the winch post. The two lift cables will be on the bottom side.
- The winch tube assembly will have to be lifted and lowered onto the winch post and post #3 as the clamps are not to be removed while assembling it in place and will need to be positioned as follows to do so.
- Slide the winch tube with mounting brackets down over the Post No. 3 and the winch post and position so the bottom edge of the clamp is at the point of the arrow.

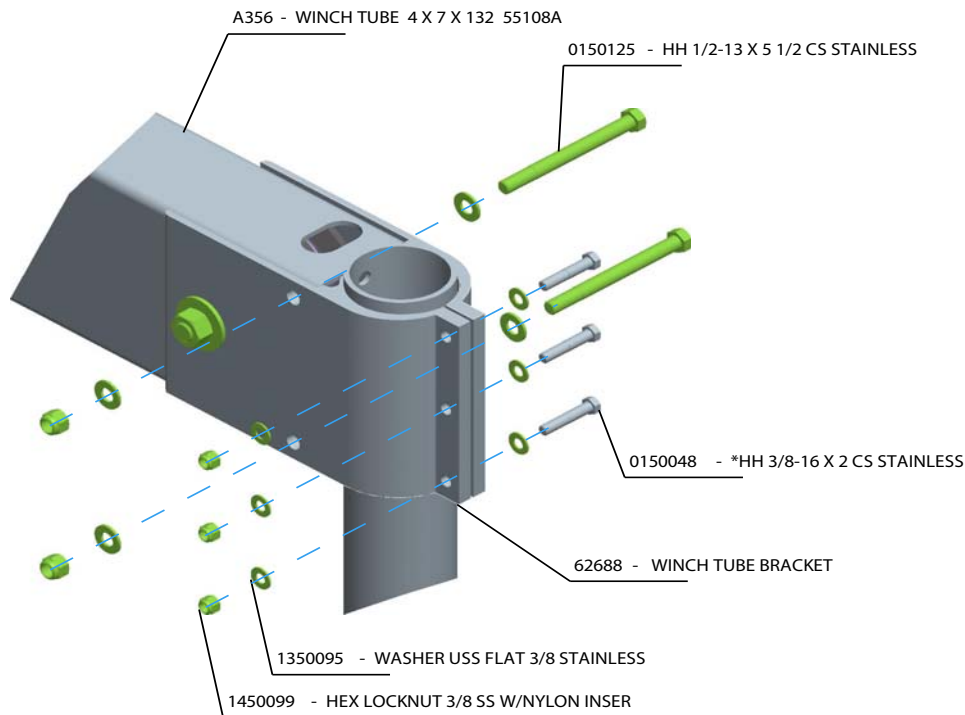

- With the winch tube into position insert two 1/2 x 5 1/2" stainless steel hex bolts with stainless steel flat washers from the inside of the hoist out and secure with another stainless steel flat washer and 1/2" stainless steel lock nut with plastic insert.
- Also insert three 3/8 x 2 stainless steel hex bolts with 3/8" stainless steel washers, again from the inside out. Secure with a 3/8" stainless steel flat washer and 3/8" stainless steel lock nut with nylon insert.
- Repeat on the other end.
- It is now time to lift the winch assembly up and lower it into the winch post and secure using a 1/2" x 4 1/4" stainless steel hex bolt with a stainless steel washer on the threaded end and a 1/2" stainless steel lock nut with nylon insert.

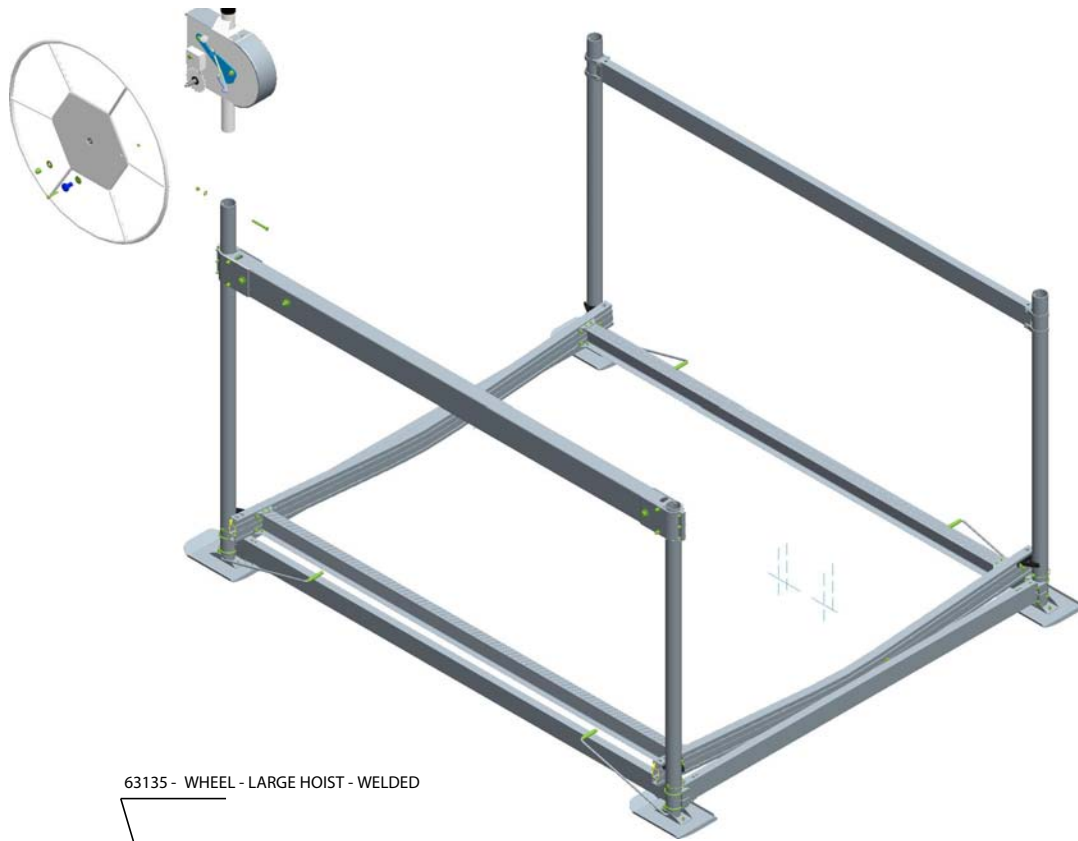

63135 - WHEEL - LARGE HOIST - WELDED

1450109 - HEX NUT 3/8-16 STAINLESS

DOUBLE REDUCTION WINCH

1450357 - HEX LOCKNUT NYLON 1/2-13 STAINLESS

1350100 - WASHER USS FLAT 1/2 STAINLESS

0150116 - HH 1/2-13 X 4 1/4 CS STAINLESS

70468 - WASHER TAPPED 1 13/16 OD X 7GA ALUM

3510001 - SPINNER KNOB

0250128 - CARR 3/8-16 X 3 GR5 STAINLESS

1350105 - WASHER USS FLAT 5/8 STAINLESS

1410299 - HEX NUT ACORN 5/8-18 BRASS

- Assemble the big wheel and remove the acorn nut and washer from the winch and discard the aluminum cover which is used to protect the threads during shipping. Spin the wheel onto the threaded shaft and secure with the washer and acorn previously removed.
- Now that the winch tube is located and secure and the winch is in place, remove the two 1/2" nuts and washers on the clamp around the winch post. Attach the wheel stop assembly onto the exposed bolts. Replace the washers and nuts just removed. Tighten.

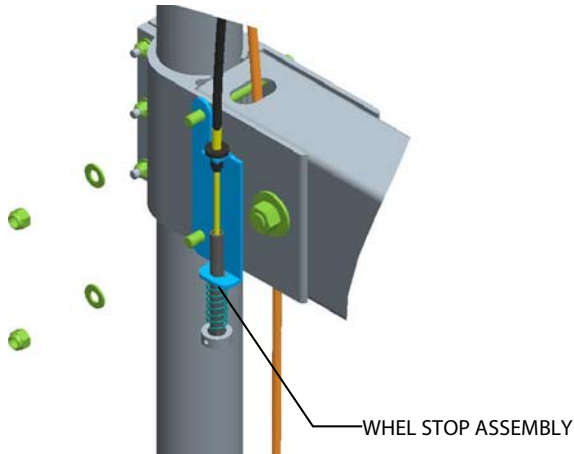

- At this time we will also need to add the wheel stop bracket to the end of the platform tube just below where the wheel stop assembly was attached using the hardware as shown below.

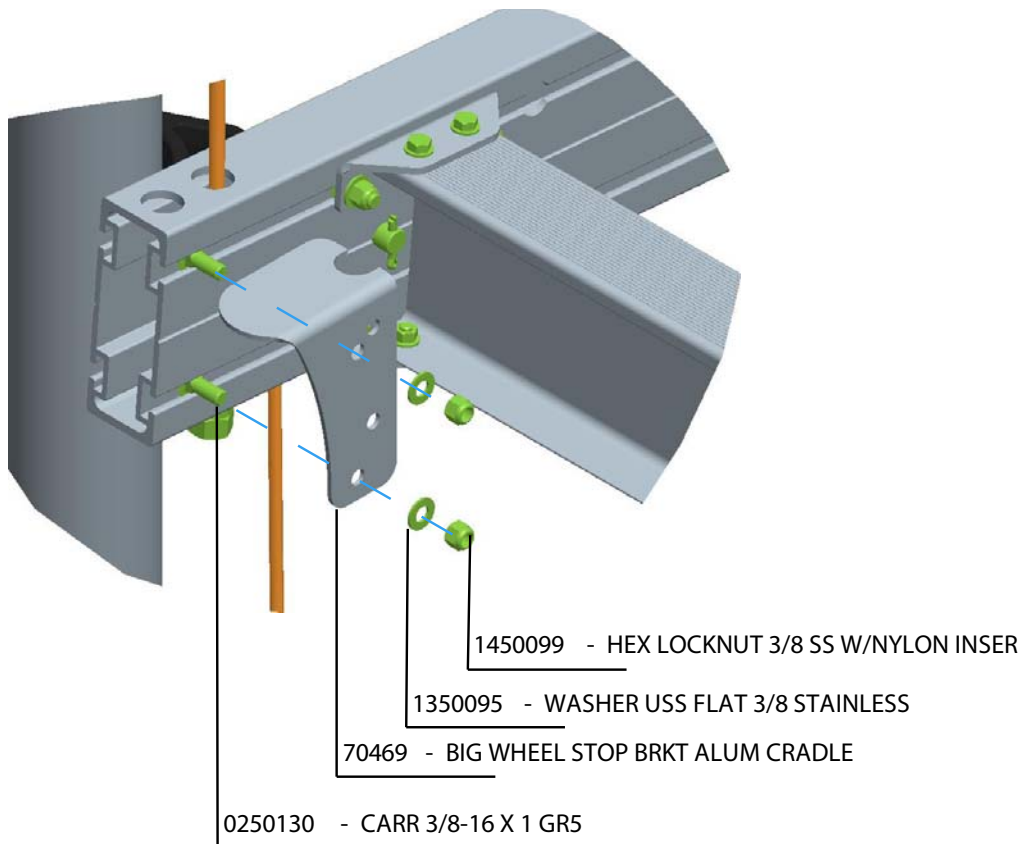

Remove the winch cover by loosening the wing nuts on both the top and bottom of the winch case. Locate the cable wedge pocket. Rotate the winch drum either clockwise or counterclockwise by turning the drive shaft until the cable wedge pocket is in the shown location. Thread the cable from the winch tube up behind the cable drum and then up into the cable wedge pocket. Form a loop in the cable and push the cable end back into the cable wedge pocket. Insert the cable wedge as shown with the narrow end down. Pull on the cable on the bottom side of the winch drum removing the slack in the cable forming the loop. Pull until the cable wedge is down in the cable wedge pocket. Replace the cover and if no canopy is to be installed add the cap to the top of the winch assembly tube.

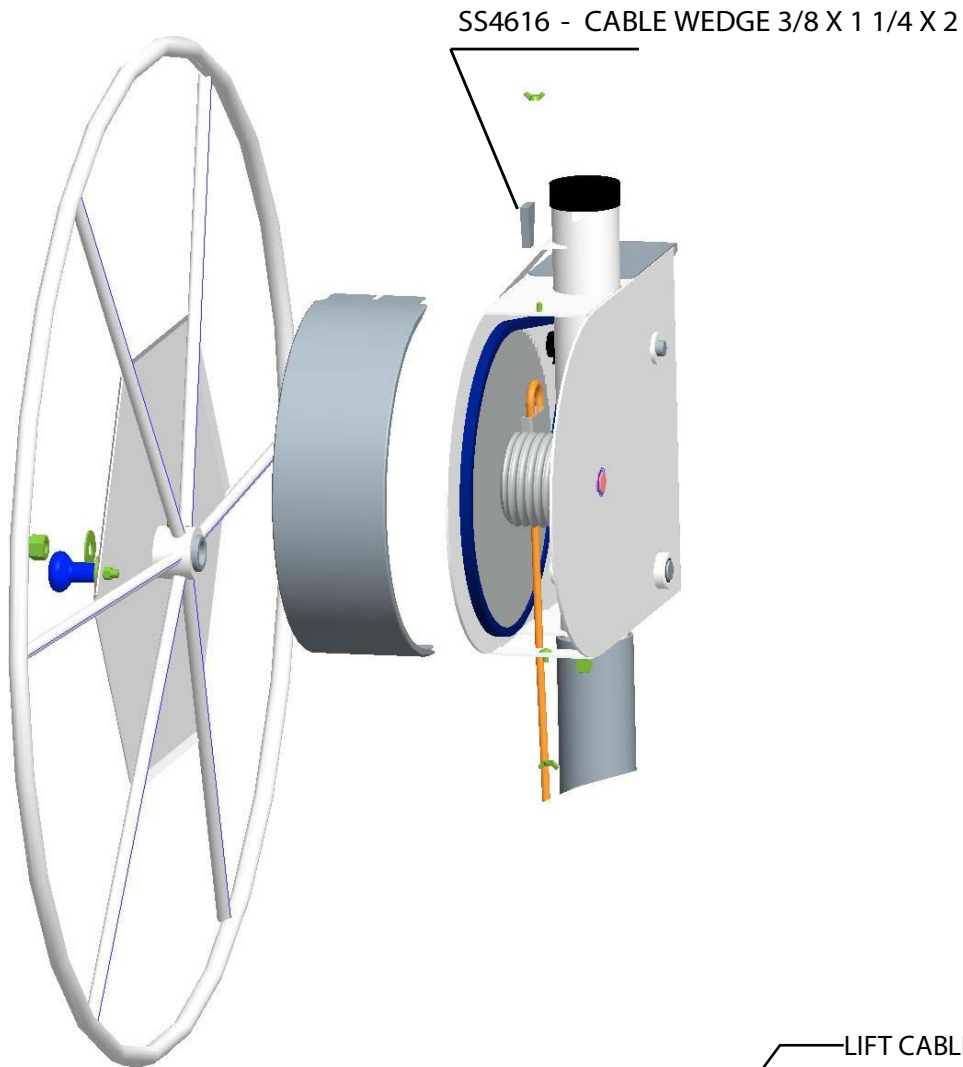

- Route the lift cable on the winch end down and insert it into the inside hole in the top of the aluminum v-cradle tube and out the bottom. Place on a 5/8" flat washer and a 5/8" brass nut. Thread the nut completely on the threads. Place on a second 5/8" brass nut and thread it against the first nut. Using two wrenches turn the two nuts into each other locking them together. Repeat this process on the other lift cable by Post No. 3 mounting this cable in the outside hole.

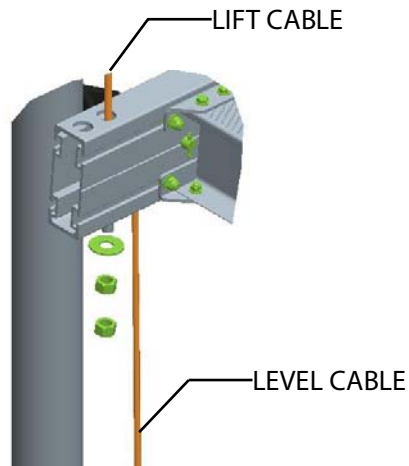

- Raise the platform approximately 30 inches from the bottom.
- With tension on the cables now move the plastic guides to 1/4" of the guide posts and winch post and secure.

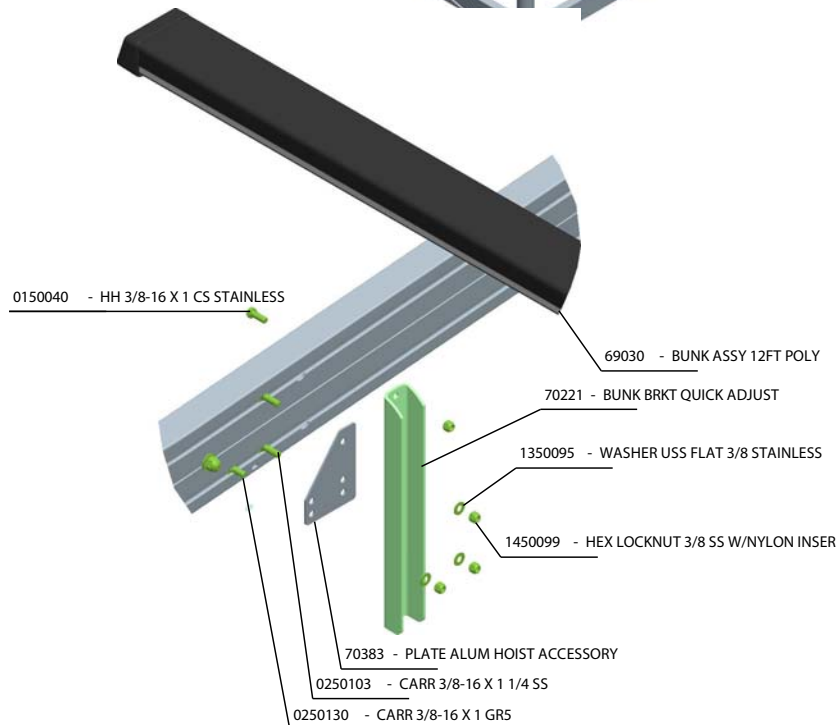
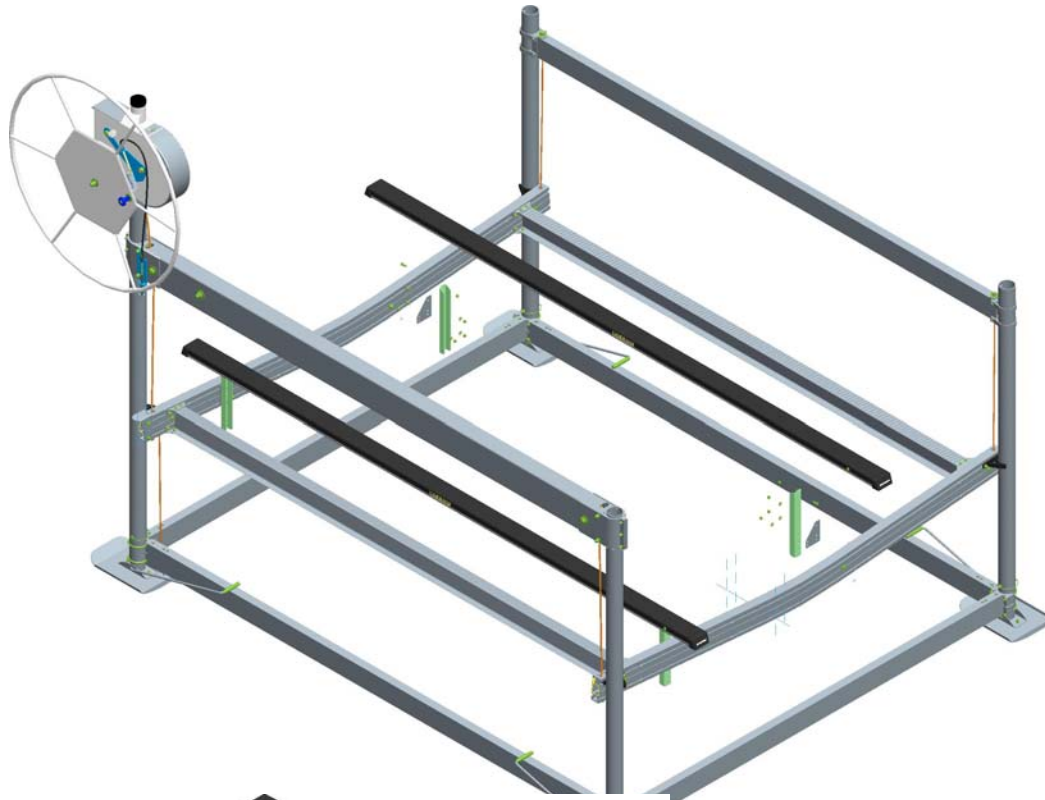

- Note the adjustable bunk brackets will be installed on the inside of the platforms as shown with the 70383 plate placed over the bolts with narrow end toward the center add adjustable bracket and secure with 3/8" stainless steel flat washers and 3/8" stainless steel lock nuts with nylon inserts.

- The motor stop must be installed on the entry end of lift.

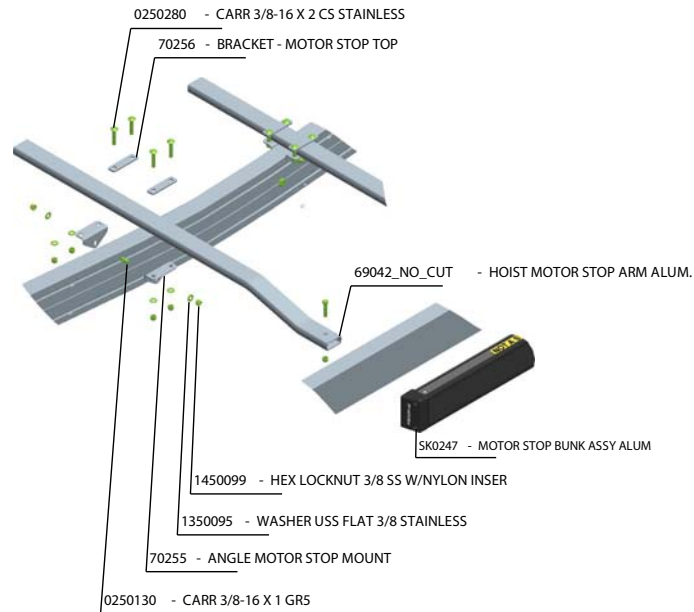
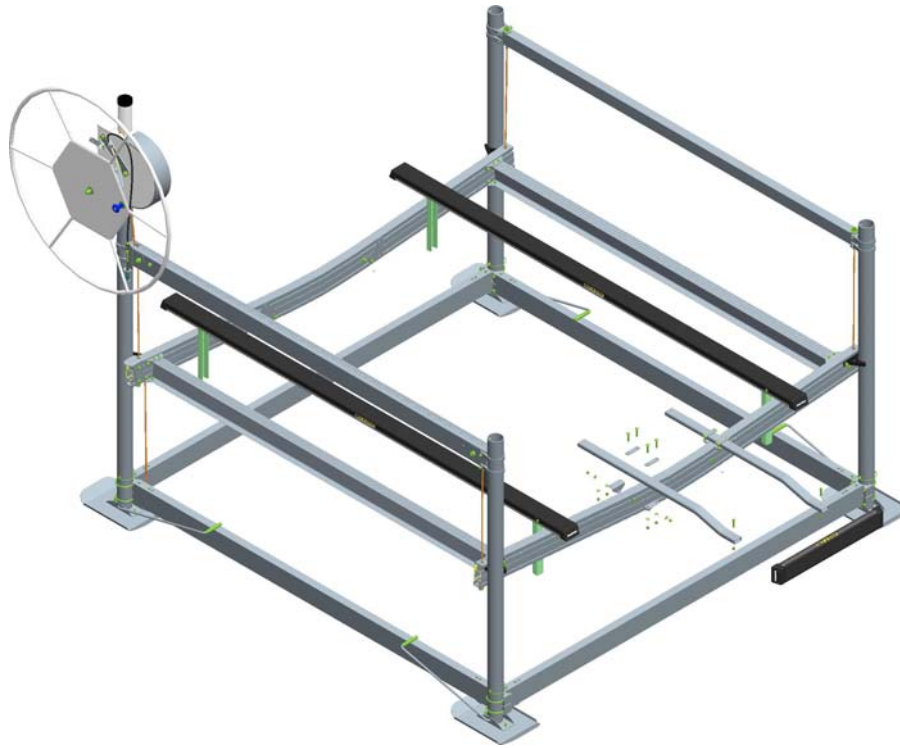

- Attach the angle motor stop mounting brackets to the aluminum platform as shown with a 3/8" x 1" stainless steel carriage bolt and stainless steel flat washers and stainless steel nylon lock nuts as shown above.
- Repeat on the remaining angle motor stop mounting brackets.
- Insert (2) 3/8" x 2" carriage bolts into the bracket – motor stop top insert into the holes on the angled bracket insert the motor stop arm tubes between the brackets and secure with 3/8" stainless steel flat washers and 3/8" stainless steel lock nuts with nylon inserts.
- Repeat with the remaining brackets
- Mount the motor stop bunk assembly to the arms. Position the brackets so the arms are equal distance from the center of the lift and secure all fasteners.

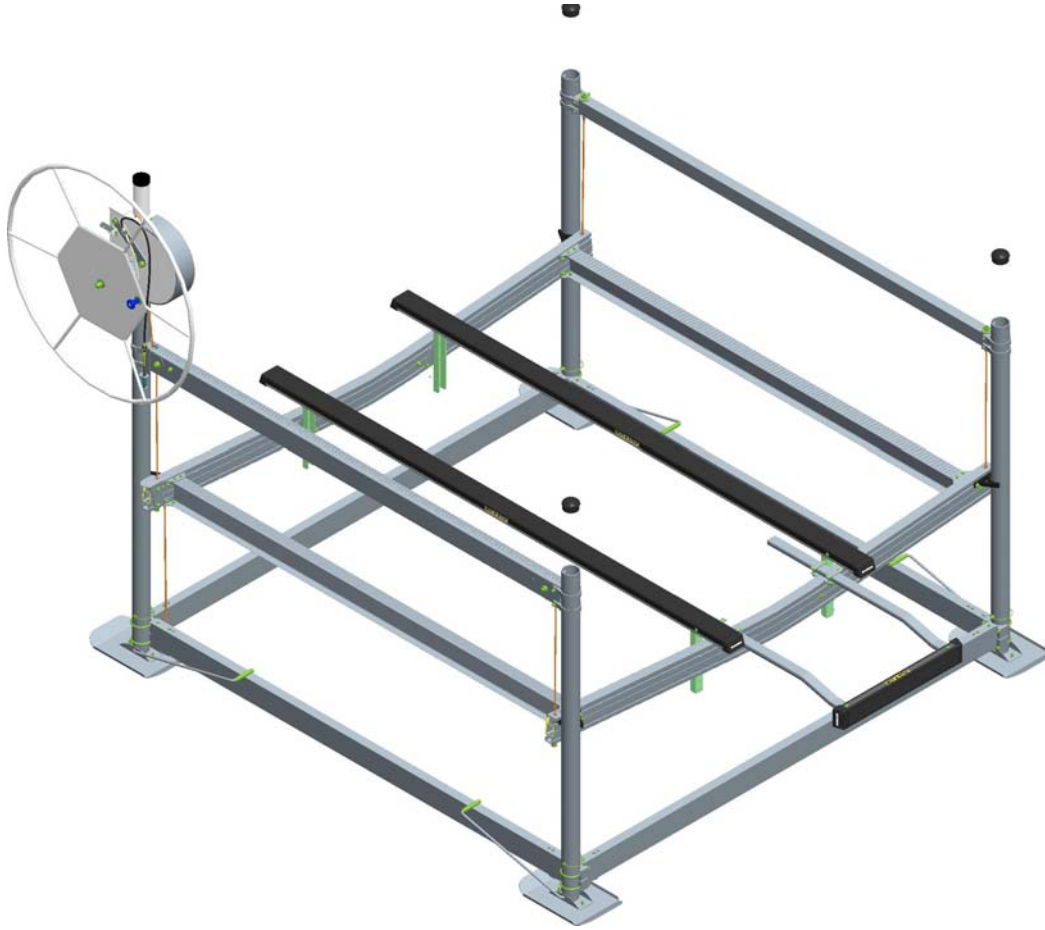

- Insert the plastic caps in Posts No. 1, 2, & 3 if a canopy is not going to be installed.

YOUR LIFT IS NOW FULLY ASSEMBLED AND READY FOR INSTALLATION.

# ADJUSTMENTS

## LEVELING THE LIFT PLATFORM

The level cables run from the corner cable brackets on the lower frame up through the lift platforms, and then upward and connect to the top side rail on the side opposite of the winch tube side of the lift. These cables are designed and built to a standard length that is compatible for a specific lift width and size. When installed according to the assembly instructions the nuts will be fully threaded onto the cable ends and they will keep the platform level in the lift. However, should the situation arise where the platform is not level in the lift, it can be adjusted as follows:

- Determine which side of the platform is high. If the platform on the top side spacer tube is high, loosen the 1" clamps securing the top side spacer tube to Posts No. 1 & 2 and slide down the post enough to make the platform level.
- If the platform on the top side spacer tube is low, loosen the 1" clamps securing the top side spacer tube to Posts No. 1 & 2 and slide up the post enough to make the platform level.

## PLATFORM CABLE ROUTING

- The level cables installed in the aluminum level lift are made of stainless steel.
- The platform is assembled as shown in the Diagram but the component parts will vary depending on the size lift.
- The cable is routed down from the top side spacer and under the pulley as shown. The cable must be contained in the pulley groove. Cable damage will occur if not retained in the groove.
- The cable is then routed through the platform tube under the bushing located inside the platform tube.
- The cable is routed in the top pulley groove on the winch tube side of the lift.
- The cable end is attached to the bottom corner cable bracket.

## Servicing

- The nuts on the cable ends are made from brass so they can be easily removed in the event the cable has to be replaced in the field.
- Check the pulleys to make sure they are turning. They **MUST TURN** at all times as the platform is being raised or lowered to prevent damage to the pulleys and/or cables.
- Manually raising the platform assembly on the top side rail side of the lift only will cause slack in the level cables creating the possibility of the cables slipping out of the pulley grooves.

Should you have any questions regarding the cables and pulleys, contact your local ShoreStation dealer.

## WINCH TUBE SERVICE INSTRUCTIONS

The winch tube assembly was pre-assembled at the factory. It is important that the internal parts and cable routings are assembled properly in order for the winch tube assembly to function properly. It also requires special tools during the assembly process. It is therefore recommended that you contact your local dealer should you ever have issues with the winch tube assembly.

In the event that you are experiencing a problem and do not have a ShoreStation dealer available to assist you, contact ShoreStation at [www.shorestation.com](http://www.shorestation.com) for assistance. You can also reach customer service by calling 1-800-859-3028. If necessary, we can supply you with a schematic drawing of the appropriate winch tube assembly for your lift. You will need to supply us with the year of manufacture and the model of your lift when you call.

## HAND WHEEL OPERATION

**WARNING: TURN THE OPERATOR'S HAND WHEEL CLOCKWISE WHEN RAISING THE PLATFORM. FAILURE TO DO SO WILL CAUSE THE BRAKE MECHANISM TO NOT ENGAGE CREATING A FREE-WHEEL SPINNING SITUATION. THIS MAY CAUSE POTENTIAL BODILY INJURY AND/OR POSSIBLE DAMAGE TO THE BOAT AND LIFT.**

### Over-cranking the Winch Mechanism

**WARNING:** Continuing to crank the winch mechanism once the platform is in its fully raised position will create tremendous internal loading of the cables, the winch tube assembly and its components. This overloading may be great enough to cause some of the internal components to fail. Once the platform has reached its' fully raised position, discontinue cranking.

New versions of the aluminum lift models with the mechanical winch system have an automatic stop mechanism built into the lift so that the wheel can not be turned once the platform has reached its fully raised position. Make sure your automatic stop mechanism is properly installed and maintained to eliminate over cranking.

Do not exceed the maximum lifting capacity of this unit. Overloading may cause mechanical failure and serious personal injury.

Do not board the watercraft on the lift while the lift is being raised or lowered.

Completely lower the lift's platform before removing the winch cover to work on or inspect the winch. Never reach through the hand wheel and manipulate any of the winch mechanism when the platform is raised.

## MAINTENANCE

**REFER TO THE PARTS MANUAL FOR YOUR PARTICULAR LIFT WHEN ORDERING REPAIR PARTS FROM YOUR DEALER.**

It is recommended that your ShoreStation lift be thoroughly inspected at the start of each season.

Check all fasteners for tightness.

Check the frame thoroughly for bent members and signs of fatigue.

Check all pulleys, they must be turning freely, show no signs of wear and are turning properly.

Inspect all cables for fraying, wearing and deterioration. Check the stress on the cable attaching ends. If any of the above signs appear, replace the cables immediately.

Check the winch mechanism to make sure it is functioning properly. A winch servicing schedule must be followed annually to prevent possible failure.

Grease the winch drive chain at the start of each season.

### WINCH MECHANISM

Remove the large hand wheel and apply a light coating of grease on the acme threads to prevent the wheel hub from seizing to the drive shaft. To remove the hand wheel, use the following instructions:

With the lift in the lowered position, remove the acorn nut and flat washer from the winch drive shaft. Turn the lift wheel counterclockwise on the drive shaft. This will thread the wheel off of the drive shaft. Remove the oilite washer, ratchet sprocket and clutch plate.

Inspect the brake disc pad for glazing on the braking surfaces. The braking surfaces can be reconditioned by using Emory cloth to clean the surfaces from rust and glazing. While cleaning, inspect the surfaces of the clutch plate for stress cracks. If stress cracks appear on the clutch plate, replace before reassembling.

Replace the reconditioned clutch plate or new clutch plate and ratchet sprocket. (Be sure the ratchet is properly positioned and aligned so it will engage the notches or teeth on the outer diameter of the sprocket.)

Place on the oilite washer. Place a small amount of grease on the threads inside the hub of the hand wheel and the acme threads on the drive shaft. A small tube of grease is supplied with your lift for your convenience. Remove the winch cover. The tube of grease is attached with Velcro to the inside of the winch case. Use this brand grease or an equivalent for the wheel hub only.

**CAUTION: AFTER MAINTNEANCE HAS BEEN PREFORMED ON THE WINCH MECHANISM, FOLLOW “CHECKING THE WINCH MECHANISM” BEFORE USING THE LIFT.**

## **ALUMINUM LIFT MODELS WITH WINCH STYLE LIFT MECHANISMS**

ShoreStation incorporates the vertical lift design in all aluminum winch style boat lifts it manufactures with a lifting capacity range of 1,500- 6,000 lb. The vertical lift design will raise the boat straight up without moving it through an arc as the platform is raised.

This style lift has a V-platform so it can be used in shallow water applications. The lift platform is lowered and raised through the use of cables to transfer the load equally to all corners.

The main lifting mechanism is in the winch tube assembly that is located on the dock side of the lift. This winch tube assembly is adjustable up and down for height so it is easier to access your boat if it is an issue. See the following instructions for adjusting.

### **WINCH TUBE HEIGHT ADJUSTMENT**

#### **For all Aluminum Vertical Lift Boat Lifts with a Mechanical Winch System**

The winch tube height can be adjusted to various heights to better accommodate your installation, making it easier for you to enter and exit your boat when it is in the lift.

Currently all assembly instructions are written to position the winch tube assembly in its highest position. This maximizes the lift height for your lift. However, there are applications where you may not be in deep, rough water. Another application may be where your dock is positioned closer than 24” to the water level. If one of the above is your situation, the winch tube can be lowered to better match your dock height. It can be lowered as follows:

1. Install the lift in position along side the dock. Level the lift and adjust so you can enter and exit the lift with your boat as desired.
2. Remove the boat from the lift and lower the platform to its lowest position. This will remove all load and tension on the winch and lift cables.

NOTE: Decals are located on the upright posts of the lift that the winch tube is attached to. These decals are positioned on the posts at the factory so that when the winch tube assembly is positioned on the upright posts at identical locations on the decals, the winch tube should be located level with respect to the other post.

**NOTE: For every inch that you lower the winch tube assembly, you will lose one inch of lift. The cable mechanism is designed that any excess cable that is created by you moving the winch tube downward will be taken up by the winch cable attached in the winch.**

#### Adjusting Instructions

3. Loosen the bolts in the clamps that attach the winch tube to the upright posts. Note that the bolts should NOT have to be removed to lower the winch tube if loosened sufficiently.
4. Using a hammer, tap the clamps slightly on the top side causing them to slide down the post. They will have a tendency to bind around the post as the winch tube is lowered so they will have to be moved together. Both ends of the winch tube need to be adjusted together. It works best to have a person on each end of the winch tube assembly so both ends can be lowered at the same time. If you are alone, lower one side about an inch, then lower the other end the same distance. Repeat this process until you have lowered it to the desired height.
5. Once the winch tube has been lowered to its desired position, tighten the clamps on one end of the winch tube assembly. When they are tightened, adjust the remaining end to a matching height using the decals on the post.

## SHORESTATION OPERATOR'S MANUAL

### ADJUSTING THE WINCH TUBE

- The winch tube can be lowered to improve the access to your boat. Lowering the winch tube will reduce the lift height of the lift.
- Remove the boat and lower the platform completely before adjusting.
- Loosen the bolts securing the clamps, lower the winch tube, then retighten bolts before the load is reapplied.

### WARNING!!

**NEVER ATTEMPT TO STOP A SPINNING HAND WHEEL. DOING SO MAY CAUSE SERIOUS PERSONAL INJURY TO ARMS AND HANDS.**

In the event that the braking mechanism malfunctions and the hand wheel begins to spin uncontrollably down, DO NOT attempt to stop it. Simply let the platform lower until the boat is in the water. NO DAMAGE will occur to either the boat or lift when doing so.

## WINCH MECHANISM

**Before placing this lift into operation, perform the following check on the winch mechanism to make sure it is operating correctly.**

**Check as follows:**

### ON SHORE TEST

- Raise the empty platform approximately one-fourth of its lifting height.
- Release the grip on the hand wheel. Winch mechanism must hold the platform in this position if operating properly.

- Repeat the above process at the one-half and three quarters raised positions. If the winch mechanism holds the platform in the set position the lift can now be installed in the water.

#### IN WATER TEST

- Raise the platform with the boat approximately one-fourth of its lifting height.
- Release the grip on the hand wheel. Winch mechanism must hold the platform in this position if operating properly.
- Repeat the above process at the one-half and three quarters raised positions. If the winch mechanism holds the platform in the set position the lift can now be installed in the water.

**In the event that the braking mechanism malfunctions and the hand wheel begins to spin uncontrollably down, DO NOT attempt to stop it. Simply let the platform lower until the boat is in the water. NO DAMAGE will occur to either the boat or lift when doing so.**

If for any reason your winch mechanism does not function as described, DO NOT tamper with the winch mechanism. Call your authorized ShoreStation dealer for assistance.

## **DO NOT OPERATE THIS LIFT WITHOUT FIRST STUDYING AND UNDERSTANDING THE INFORMATION IN THIS OWNER'S MANUAL**

- This lift is a piece of heavy equipment and must be treated with respect and good judgment when operating.
- Make sure everyone who will operate this lift know and understands the proper operating procedure.
- Never exceed the maximum lifting capacity of this lift. Over loading may cause mechanical failure and serious injuries.
- Keep everyone clear from the lift and its moving parts when raising and lowering the platform.
- Never remove the winch cover unless the platform is in the fully lowered position.
- Never reach through the hand wheel to manipulate any part of the winch mechanism while the platform is raised.
- DO NOT allow anyone to play on or near the lift.
- Remove the drain plug in the boat when not in use, especially when leaving it for an extending period of time or signs of rainy weather and the lift is not equipped with a canopy.
- Service annually to avoid possible failures due to lack of maintenance. See Service section of this manual for details.
- Check all cables for fraying, wear, and stress on the cable ends. Replace cables immediately when these signs appear.
- Check all sheaves while raising and lowering the platform to make sure they are all turning and operating properly.
- Make sure that the lift is installed level. Severe out of level installation may cause the lift platform to hang up and may cause serious personal injury.
- DO NOT work on your boat while it is in the lift.
- Check the nuts on the cable end occasionally to make sure they have not loosened and turned off the threads during operation of the lift.
- NEVER TRY TO STOP AN UNCONTROLLABLE HAND WHEEL BY REACHING IN OR GRABBING THE SPINNING WHEEL. Allow it to spin down freely by itself. Doing so will neither damage the your boat or lift.
- Never raise up on the platform when trying to move or transport the lift on land or in the water. Doing so may cause the cables to become misaligned with the sheaves causing excessive damage to the lift components when the platform is raised with the winch mechanism.
- Never stand or walk on the lift platform while it is in the raised position.
- Follow in instructions outlined in the assembly manual when adjusting the winch tube for height.

## SAFETY MAINTENANCE

- Inspect the lift annually to make sure it is in operating condition.
- Check for damaged or broken lift component parts. Replace if necessary.
- Tighten all bolts and nuts.
- Inspect all cables for fraying, wearing, and deteriorating. If any signs appear, replace cables.
- Check all pulleys and make sure they are turning freely and are not damaged.
- Maintain the winch mechanism as described in the section WINCH MAINTENANCE.

## WINCH MAINTENANCE

Maintain the winch mechanism as follows:

- Lower the lift platform to its lowest position.
- Turn the acorn nut in the center of the wheel counterclockwise to remove it and the flat washer. Remove the hand wheel by turning it counterclockwise until it threads itself off of the acme threads on the shaft.
- Remove the remaining brake component parts by raising the clutch dog to disengage it from the clutch sprocket, then sliding them off the shaft.
- Check the surfaces of the clutch sprocket, clutch plate, and the flat disc surface of the drive shaft for any glazing or corrosion.
- Use emery cloth to remove any glazing or corrosion that may be on the surfaces. This will also roughen up the surfaces for better braking.
- If surfaces can not be restored, replace with new parts.
- Once old parts are cleaned or are replaced with new parts, reassemble as follows:
- Place the clutch plate onto the drive shaft until it contacts the flat disc welded to the drive shaft.
- Slide the clutch sprocket into position. Raise the clutch dog up and forward so that the clutch sprocket can be installed completely against the clutch plate. The clutch dog must engage the teeth of the clutch sprocket in order for the brake system to operate properly.
- Slide on the oilite washer.
- Remove the small tube of grease that is attached inside the winch case with Velcro. Apply a small amount of grease to the acme threads as shown. DO NOT over grease or to get grease on the surfaces of the clutch sprocket and clutch plate. Doing so will cause the brake system to not work properly.
- Apply a small amount of grease to the acme threads inside the wheel hub.
- Reattach the grease tube to the inside of the winch case with the Velcro provided for storing until next season.
- Thread the hand wheel back onto the acme threads of the drive shaft by turning clockwise. Replace the parts by reversing the process in Step W1.

## FASTENER CHANGEOVER STAINLESS STEEL TO BRASS

The following fastening hardware will be changing from stainless steel to brass in the pre-packaged bags and in the accessory kits and will no longer require the use of an anti-seize compound on the threaded hardware.

<u>Stainless Steel Components</u>	<u>Brass Replacement Components</u>
1450079 HEX LOCKNUT 5/16-18 SS W/NYLON	1440365 HEX LOCKNUT 5/16-18 BRASS /NYLON
1450099 HEX LOCKNUT 3/8-16 SS W/NYLON	1440366 HEX LOCKNUT 3/8-16 BRASS/NYLON
1450109 HEX NUT 3/8-16 STAINLESS	1410403 HEX NUT 3/8-16 BRASS
1450357 HEX LOCKNUT 1/2-13 SS W/NYLON	1440367 HEX LOCKNUT 1/2-13 BRASS/NYLON

The assembled components such as leg assemblies, winch tubes, and v frames that are assembled at Midwest Industries Inc. and should not need adjustment will continue to be assembled with all stainless steel components.