

CF36-144 & CF40-144 Canopy Frames Fitting:

Hydraulic Hoist Models: SSV150144 HYD & SSV150144AL HYD

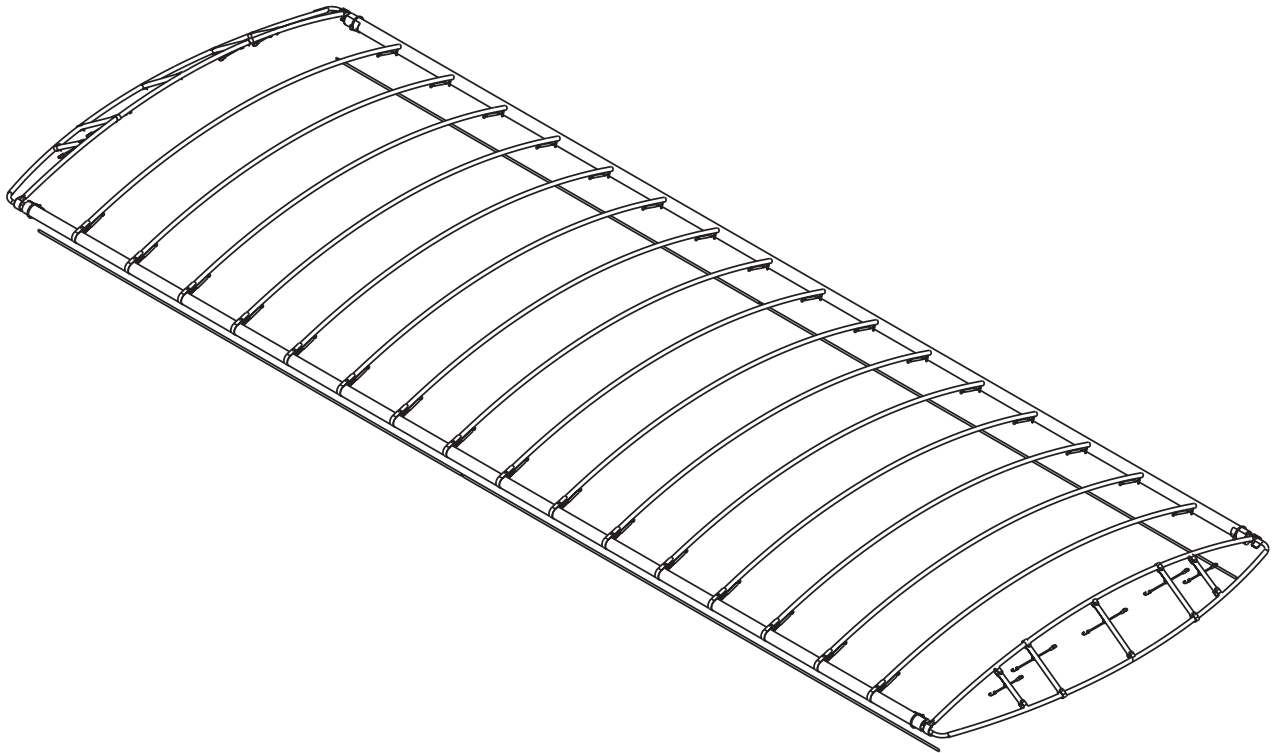

MODEL	WIDTH (inches)	LENGTH (foot.)	NUMBER OF HOOPS	HOOP PART NUMBER	SPLICE INCLUDED (A180)	SIDE FRAME TUBE NUMBER(S)		STAINLESS PULL STRAP NUMBER(S)	
CF36-144	144	36	20	67506	N	3900494	-	67237	67668
CF40-144	144	40	22	67506	Y	3900527	68350	68351	68351

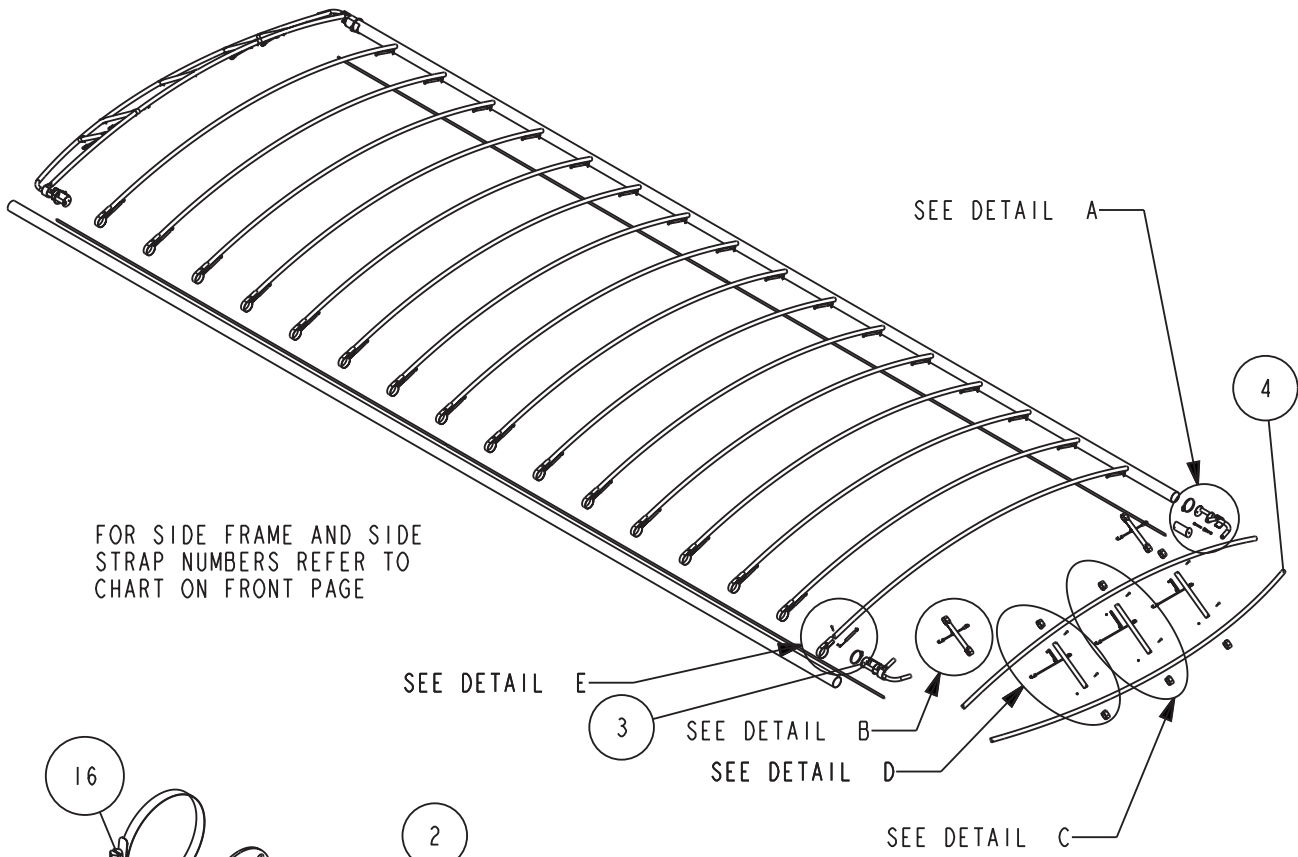

FOR SIDE FRAME AND SIDE STRAP NUMBERS REFER TO CHART ON FRONT PAGE

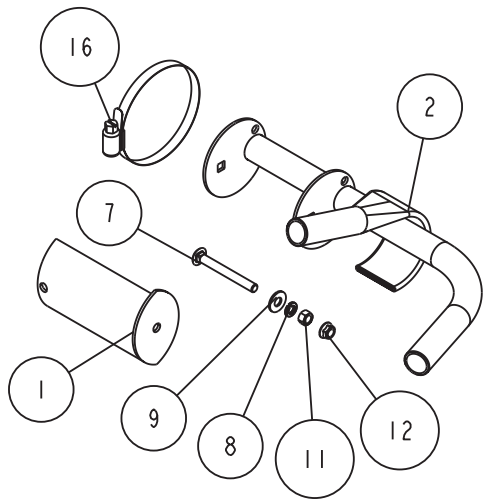

DETAIL A
SCALE 0.125

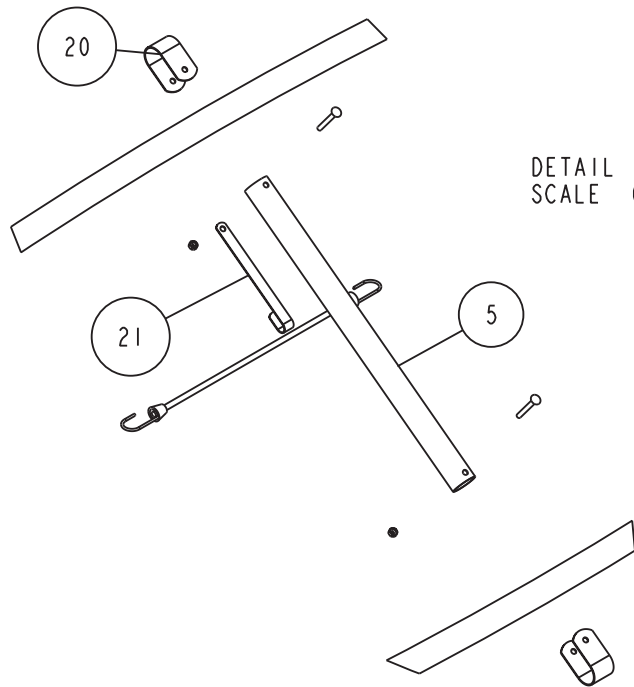

DETAIL C
SCALE 0.100

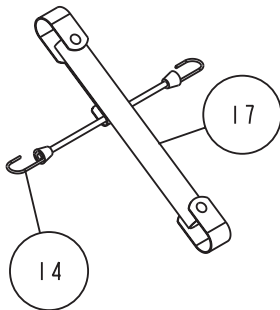

DETAIL B
SCALE 0.100

BILL OF MATERIALS		
ITEM	PART #	DESCRIPTION
1	67326	SIDEFRAE TUBE STOP WMENT
2	67330	CANOPY END WMENT - RIGHT
3	67331	CANOPY END WMENT - LEFT
4	67506	CANOPY BOW - 50120 CANOPIES
5	67507	CANOPY END SPACER TUBE X 20 1/2IN.
6	0210051	CARR 1/4-20 X 2 1/4 GR5
7	0210145	CARR 3/8-16 X 3 1/2 FULLTHRD GR5
8	1340030	LOCKWASHER 3/8 S/T MED ULTRASEAL
9	1340095	WASHER USS FLAT 3/8
10	1410049	HEX NUT FINISH 1/4-20
11	1410109	HEX NUT 3/8-16
12	1440101	FLANGE LOCKNUT SMALL 3/8-16
13	2121201	SPRING CANOPY SIDE.095 WIRE ZP
14	3510021	SHOCK CORD 5/16X15 BUNDLED IN 4
15	3510234	SHOCK CORD 5/16X20 BUNDLED IN 2
16	3610162	HOSE CLAMP N-STYLE STAINLESS
17	A171	CANOPY END SPACER TUBE X 12 3/4IN.
18	A173	HOOP MTG BRKT LOOP
19	A176	BUNDGY CORD LOOP
20	A177	END HOOD LOOPS
21	A185	CENTER BUNDGY CORD LOOP C22A
22	A382	CANOPY END SPACER TUBE X 19 IN.

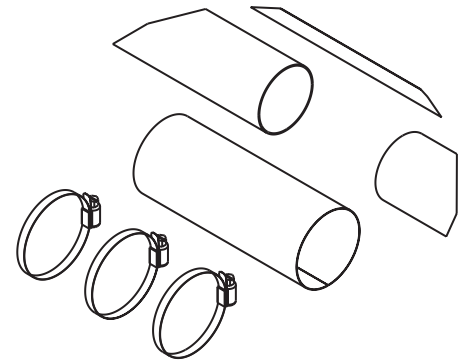

SPLICE DETAIL FOR CF40-144
SCALE 0.100

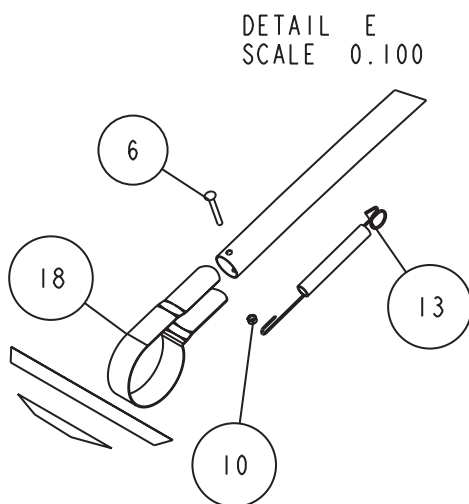

DETAIL E
SCALE 0.100

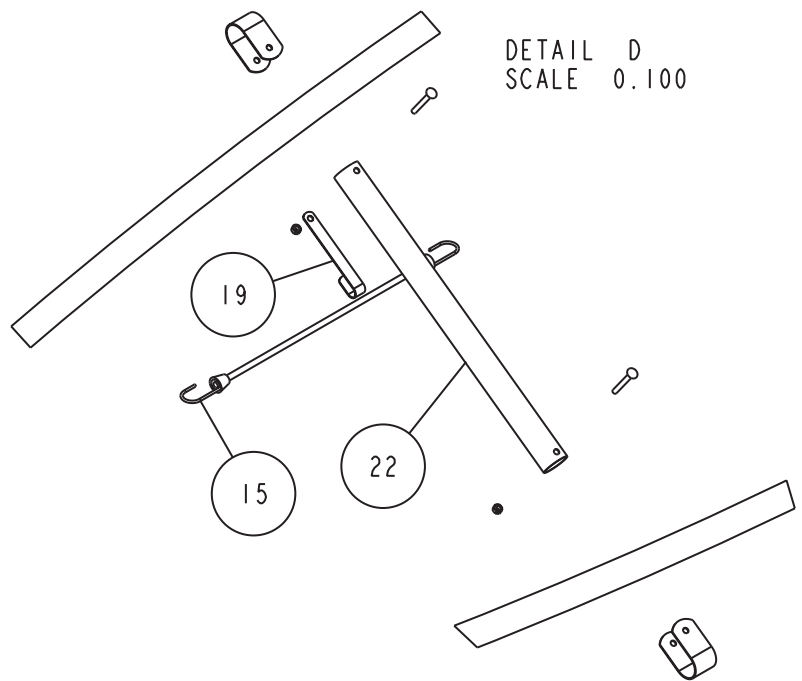

DETAIL D
SCALE 0.100

ASSEMBLY INSTRUCTIONS

Break bundles and hardware box. Sort all parts according to size. Depending on the model ordered, you may have extra parts.

END HOOD ASSEMBLIES

Locate the adjustable canopy end assemblies. Note that there are two- right and two- left hand assemblies. (See Detail A.) Next locate two of the canopy bows. Using one each of the right and left hand assemblies, place the pieces on the floor or ground. Insert one end of the two canopy bows over the round tubes on one of the adjustable canopy end assemblies. Note that one bow will lay flat on the floor while the other will curve upward in the form of the canopy once it is completely assembled. Next insert the other ends of the canopy bows onto the round tubes on the second adjustable end assembly. Make sure that the canopy bows are slid onto the round tubes as far as they can without jamming or driving the one.

Mark the centers on the two canopy bows. Locate one of the 67507 - 20-1/2" canopy end spacer tubes (Item 5 in Detail C). Attach it to the canopy bow that is laying on the floor at the center location just marked. Secure together with an end hood loop and 1/4" x 2-1/4" carriage bolt provided and as shown in Detail C. Secure the other end of the spacer tube to the top bow with a second end hood loop and 1/4" x 2-1/4" carriage bolt. Once the bolt is inserted through the end hood loop, place on a Ref. No. 21 - A185 long bundgy cord loop onto the bolt before the nut is threaded on. Tighten the nuts just installed. Locate two of the A172- 16" canopy end spacer tubes. Attach one end of the 16" canopy end spacer tubes to the canopy bow laying flat using another end hood loop, 1/4" x 2-1/4" carriage bolt and hex nut. Rotate the canopy end spacer tube so it aligns with the top canopy bow. It may be necessary to slide the canopy spacer tube either in or out so it will reach the top bow. Using another end hood loop, attach the other end of the canopy end spacer tube to the top bow. Once the 1/4" x 2-1/4" carriage bolt is inserted slip on one of the A185- long bundgy cord loops and secure with a 1/4" hex nut. Attach another A172- 16" canopy end spacer tube on the other side of this end hood assembly following the above instructions.

Locate two of the A382 - 19" canopy end spacer tubes. Attach one end of the 19" canopy end spacer tubes to the canopy bow laying flat using another end hood loop, 1/4" x 2-1/4" carriage bolt and hex nut. Rotate the canopy end spacer tube so it aligns with the top canopy bow. It may be necessary to slide the canopy spacer tube either in or out so it will reach the top bow. Using another end hood loop, attach the other end of the canopy end spacer tube to the top bow. Once the 1/4" x 2-1/4" carriage bolt is inserted, slip on one of the A185- long bundgy cord loops and secure with a 1/4" hex nut. Attach another A382 - 19" canopy end spacer tube on the other side of this end hood assembly following the above instructions. Tighten.

Repeat the above process on the other end hood assembly.

FRAME ASSEMBLY INSTRUCTIONS

Locate the four 4" side frame tubes. Note that there are two

different lengths except for the CF36. It has one long side frame tube for each side. Identify a smooth flat surface that they can be laid on during assembly because it makes the process much easier to accomplish. Measure and place a mark at 6" from one end of each of the side frame tubes. Loosen three of the stainless steel hose clamps large enough so they will slide over the side frame splice, See splice detail. Mate the marked ends of a short and long side frame tube together. Slide the splice onto the first side frame tube until it meets the 6" mark. Place the second side frame tube into the splice until the ends of the side frame tubes are butted together or touching each other. **Note that butting the side frame tubes together is very important because it adds considerable strength to the joint once it is fully assembled and tightened properly. Placing the butted ends of the side frame tubes in the middle of the splice is also important.**

Repeat the above process on the other side frame tube.

Tighten the stainless steel hose clamps evenly and securely around the side frame splice placing two of the clamps at the very ends of the side frame splice and one in the center of the splice where the ends of the side frame tubes meet inside the splice.

The frame is easiest assembled when it is assembled on four sawhorses or something of this height. Place the two side-frame tubes on the sawhorses located at a spacing that is comparable to the width of the canopy once it is assembled. Place the two side frame tube assemblies so the splicers are directly across from each other (long side frame tubes are at same end of canopy). Insert the two end hood assemblies just assembled into the ends of the 4" diameter side frame tubes. This will properly space the tubes and keep them positioned while the balance of the bows are assembled to the side frames. Make sure the adjustable end hood assemblies are slid completely in and against the end of the side frame tube. Secure in this position by placing a stainless steel hose clamp around the side frame tube and also around the end hood tube stop weldment approximately 1" from the end of the side frame tube. Position the tightening mechanism on the clamp so it is located on the inside of the side frame tube and in a position that won't interfere with the canopy cover when it is pulled around the side frame tube during installation.

The canopy bows are to be spaced on 24" centers. Using a tape measure mark the side frame tube at 24" intervals the full length of the side frame tubes.

Locate the balance of the canopy bows. Attach them to the side frames using the hoop mounting bracket loops provided. Note that they have to be formed around the side frame tube when assembling. Align the hole in each end of the hoop mounting loop with the holes in the end of the canopy bow. Secure together using 1/4" x 2-1/4" carriage bolts and hex nuts. Thread on the nuts but do not tighten until instructed.

Repeat the above process on all of the canopy bows. Once they are all attached to the side frames, relocate them so they are on the 24" marks identified earlier. **Check the canopy frame for square by measuring the framework as shown in Diagram AA. This is very important in order for the vinyl cover to fit properly when it is installed.**

CHECKING FOR CANOPY FRAME SQUARE

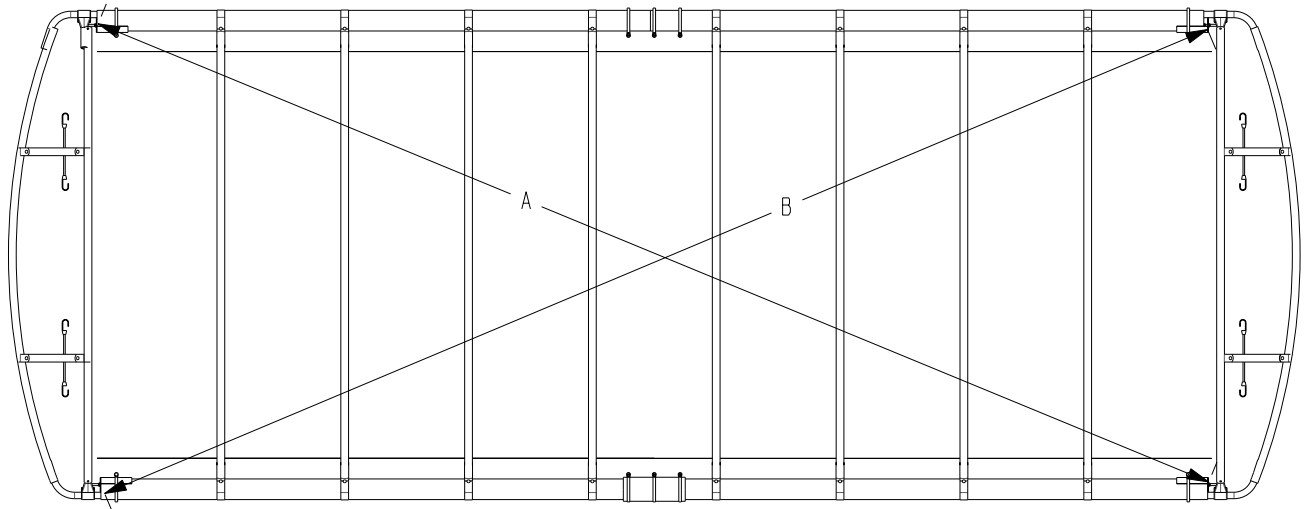

Diagram AA

Check for square by using a tape measure or string. Measure from one end of the side frame tube on one side of the framework to the other side frame tube on the other side of the framework.

Measurements A and B must match each other in order for the framework to be square. If they don't, slide one side frame either forward or backward until matching measurements are achieved. Once achieved, tighten all of the bolts attaching the canopy bows to the side frames. the framework assembly is now complete.

Pull a tape measure or string from the opposite ends of the canopy side frames across the framework as shown in the above diagram.

The canopy post assembly and installation instructions are supplied with the canopy post bundles and are located in the support cup box. Please use these instructions to attach the canopy posts to your hoist.

The following canopy post bundles are required to fit the following hoist.

<u>Hoist Model</u>	<u>Canopy Post Required</u>	<u>Consists of Bundles</u>
SSV150144AL HYD	CP90J	67678, 68317
SSV150144 HYD	CP90H	67567, 68317

Once the canopy posts have been installed on your hoist continue to attach the canopy frame and vinyl as follows.

ATTACHING THE CANOPY FRAME TO THE CANOPY POSTS

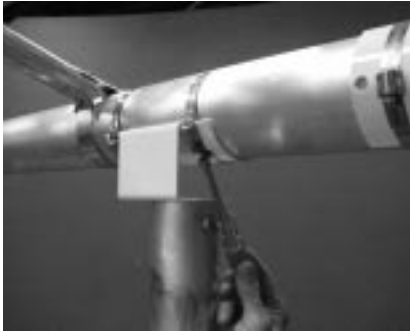

Determine the end of the hoist that your boat will enter the hoist. This is the same end that the motor stop will be mounted on. Your boat will then be positioned on the hoist so that more boat will be extending forward of the hoist upright post than what will be extended to the rear. This is important because you will want to position the canopy side frames so that the longer section of side frame extends to the front as well. This allows the splice in the side frame to be positioned more in the center of the support cups resulting in more strength. Once the canopy is properly oriented as just mentioned, raise the canopy frame up and place it so the side frame tubes are resting in the support cups on top of the canopy posts. Position the canopy frame to the proper position to best protect your boat by sliding it either forward or backward in the support cups. Also the framework should be checked again for being square by the process discussed earlier. It is possible that this may have changed in the process of raising it into position. When the desired position is achieved secure it to the support cups by placing the large stainless steel adjustable hose clamps around the support cup and the canopy side frame. Two hose clamps should be placed on each end of each support cup. Place the hose clamps so that the tightening mechanism of the clamp is located on the inside portion of the canopy side frame tube. Tighten. The tightening mechanism is to be located in this position so that it doesn't interfere with the cover when it is installed.

NOTE: The CF36-144 is shipped standard with one HA0008 Brace Bundle that is used to support the long section of the canopy frame that extends over the front of the hoist. The CF40-144 is shipped with two HA0008

Brace Bundles, one to be used on each end of the hoist. The assembly instructions are included with the HA0008 Brace Bundles.

These Brace Bundles must be installed before the vinyl is placed on the frame.

INSTALLING THE VINYL COVER TO THE FRAME



Remove the vinyl cover from the box. Unroll the vinyl cover down the side frame as shown. When completely unrolled, unfold the cover across the canopy bows and pull down over the framework.

Note that there are two different length bundy cords. The two longer bundy cords are to be used on the center canopy end spacer tube in Detail C. The shorter bundy cords can be used on all other locations. Attach one end hook of a bundy cord to the grommet strap by hooking it into an eyelet provided in the grommet strap sewn into the end hood of the cover. Stretch the bundy cord up over the hook end of the end hook loops installed in the end hood assemblies, then attaching the other end of the bundy cord into another grommet in the grommet strap that corresponds. Note that the grommets are positioned so that the bundy cords will pull evenly to each side when they are installed. The very end bundy cords are hooked into the grommet provided and then are wrapped up over the canopy bow one wrap or two to use up the excess length. Attach all of the bundy cords on both ends.

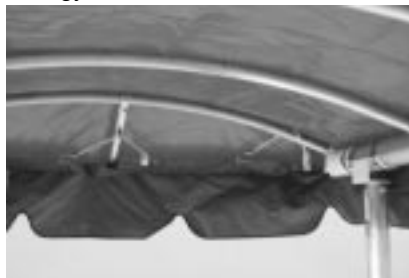

CANOPY END HOOD ADJUSTMENT

Your new canopy frame has adjustable end hood brackets which allow the frame to be adjusted a total of 1-1/2" shorter or 1-1/2" longer from its normal shipped position. This allows you to adjust your frame to fit the cover for length should it need adjusting. The following instructions will assist you in adjusting the frame length.

1. Loosen the nuts on the adjusting bolts located in the end of the side frame tube weldments. Doing so will shorten the overall length of the frame.
2. The frame can be lengthened to fit the cover by tightening the nuts on the bolts in the side frame tube stop weldments just loosened in Step 1. Turn clockwise. As the nut is threaded onto the bolt it will pull the end hood out of the side frame thus increasing the length of the canopy framework. Continue to lengthen the frame until it is the right length to fit the cover.
3. Once the proper length for the frame has been achieved, stop turning the nut. Adjustment is complete.



Place the pull straps into the side pockets of the vinyl cover by sliding them into the ends. Snap the small hook end of the springs through the vinyl material of the side straps so it catches the stainless steel side strap just installed. They need to be positioned directly under the canopy bows. Once all of the springs have been positioned, begin hooking the other end of the springs into the hole provided in the bottom side of the canopy bows as shown. It works best if you begin attaching the springs in the middle of the canopy lengthwise and then attach them as you go towards the ends of the cover.

Installation is complete.

CANOPY COVER (VINYL) MAINTENANCE

This canopy contains a mildew retardant. Please follow these recommendations to insure that this agent is not destroyed and that the vinyl will not be damaged.

1. Ordinary oil and dirt can be removed with soapy water such as laundry detergent. Apply with a mop, sponge, brush or cloth followed by a clear-water rinse. Stubborn spots can be removed by using rubbing (Isopropyl) alcohol in a well-ventilated area, away from open flames. **DO NOT USE** gasoline, kerosene, methyl ethyl Keytone (MEK) or other solvents or bleaches.
2. Remove canopy when hoist is in storage. Make sure canopy is dry before folding and store in a warm, dry location.

WARRANTY

Refer to your **ShoreStation** Owner's Packet for warranty information.

