

### SS1053DSE / SS10531DSE Dock Mount Hoist with Electric Drive Winch

Your **Shore-Station** PWC Boat Hoist is designed to give years of dependable service. Following the instructions in the operator's manual will insure its dependability and more important, **YOUR** safety. Read through this entire operator's manual before attempting to operate your hoist. Our goal is your safety - help us help you by knowing and observing the operating precautions and limitations you will find listed herein. If you do not understand any of these instructions, please ask your dealer for his personal attention to your questions.

Midwest Industries, Inc.  
Ida Grove, IA 51445

#### SS1053DSE / SS10531DSE Bundles Required

##### SS1053DSE Dock Mount Hoist 1000 lbs.

- 66003 Lower Frame Wment 853/8531
- 66027 Bunk Bundle 853/8531
- 68514 Hardware Box 1053/10531DSE
- 67424 Leg Bundle SS853DSE
- 66033 Platform Bundle 853/8531

##### SS10531DSE Dock Mount Hoist 1000 lbs.

- 66003 Lower Frame Wment 853/8531
- 66027 Bunk Bundle 853/8531
- 68514 Hardware Box 1053/10531DSE
- 67427 Leg Bundle SS8531DSE
- 66033 Platform Bundle 853/8531

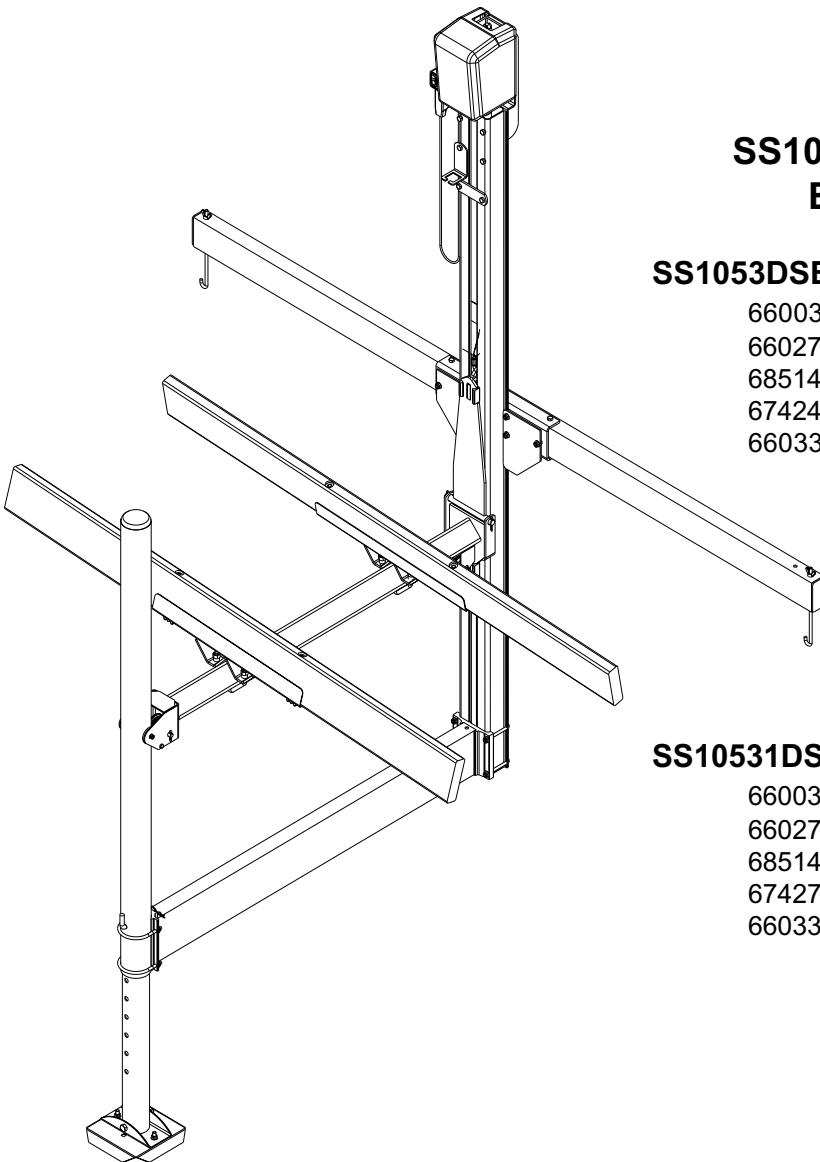

# SS1053DSE / SS10531DSE Material List

ITEM	PART #	DESCRIPTION	QTY	NOTE
1	62538	BUNK CHANNEL WMENT LEFT	1	
2	62550	SQUARE BASE PAD	1	
3	63435	BUNK CHANNEL WMENT RIGHT	1	
4	63732	1/2" PULLEY PIN	1	
5	65285	PWC DOCK MOUNT TUBE	1	
6	66003	LOWER FRAME WMENT - DOCK MTG HOIST	1	
7	66006	UPPER LIFT ARM WMENT	1	
8	66014	PLATFORM WELDMENT - DOCK MOUNT	1	
9	66015	GUIDE POST TUBE	1	
10	66016	LEG ADJUSTMENT PIN	1	
11	66017	WINCHPOST MOUNTING CHANNEL	1	
12	66018	HOIST ATTACH PLATE	2	
13	66019	STOP PLATE	1	
14	66021	WINCH POST EXTRUSION - 90"	1	A
15	66023	PULLEY SPACER BUSHING	2	
16	66025	BUNK ASSY - LEFT 853/8531	1	
17	66026	BUNK ASSY - RIGHT 583/8531	1	
18	66033	PLATFORM ASSEMBLY SS853/8531DS	1	
19	66034	PLASTIC GUIDE WASHER - 853/8531	2	
20	0110019	HH 1/4-20 X 4 1/2 CS GR5 ZP	1	
21	0110056	HH 3/8-16 X 3 1/4 CS GR5	2	
22	0110059	HH 3/8-16 X 3 3/4 CS GR5	2	
23	0110118	HH 1/2-13 X 4 1/2 CS GR5	1	
24	0120316	SCREW(PROJECTION WELD) 1/4-20 X 1/2	2	
25	0140040	HH 3/8-16 X 1 CS GR5	2	
26	0210102	CARR 3/8-16 X 1 GR5	6	
27	0210139	CARR 3/8-16 X 6 FULL THREAD GR5	4	
28	0310295	SUB 3/8 X 5 3/16 X 3 7/8	2	
29	0320101	3/8-16 X 3 7/8 X 3 7/8 ROUND U-BOLT	2	
30	0330000	1/2-13 X 4 19/32 X 3 3/4 V-BOLT	2	

31	1010073	3/8-16 X 10 1/2 HOOK BOLT	2	
32	1310020	LOCKWASHER 1/4 S/T MED	2	
33	1340095	WASHER USS FLAT 3/8	1	
34	1410049	HEX NUT FINISH 1/4-20	2	
35	1410059	HEX LOCKNUT 1/4-20 GRA	1	
36	1410109	HEX NUT 3/8-16	1	
37	1410110	WING NUT 3/8-16	6	
38	1440101	HEX LOCKNUT FLANGE 3/8-16 W/T&T	18	
39	1440102	HEX LOCKNUT FLANGE 1/2-13 W/T&T	1	
40	1440179	HEX LOCKNUT 1/2-13 GRA	4	
41	1510078	COTTER KEY 3/16 X 1	4	
42	1520082	COTTER KEY 3/16 X 1 1/2	2	
43	1540300	HITCH PIN CLIP #7	1	
44	1910048	PULLEY PIN	1	
45	2210171	CHAIN QUICK LINK W/5/16 OPENING	1	
46	3110351	CABLE LEVEL III 1/2" STAINLESS	1	
47	3510083	PLATFORM PULLEY W/BRONZE BUSHING	2	
48	3510126	SLIDE BLOCK - PWC DOCK MOUNT	2	
49	3810097	SPACER .5151D X 11/16OD X 7/16 LONG	4	
50	3910024	BUNKWOOD 2 X 6 X 12FT FIR	2	
51	A102	ADJUSTABLE LEG 3 1/8OD X 30 1/2	1	
52	A104	ALUM BASE PAD CHANNEL CLAMP	1	
53	A389	BLACK PLASTIC CAP	1	
54	HA1221	ELECTRIC WINCH KIT	1	
55	S-547	2X4 SL PLASTIC END CAP	2	

### NOTES

A For SS10531DSE use 66022 WINCH POST EXT 120 IN

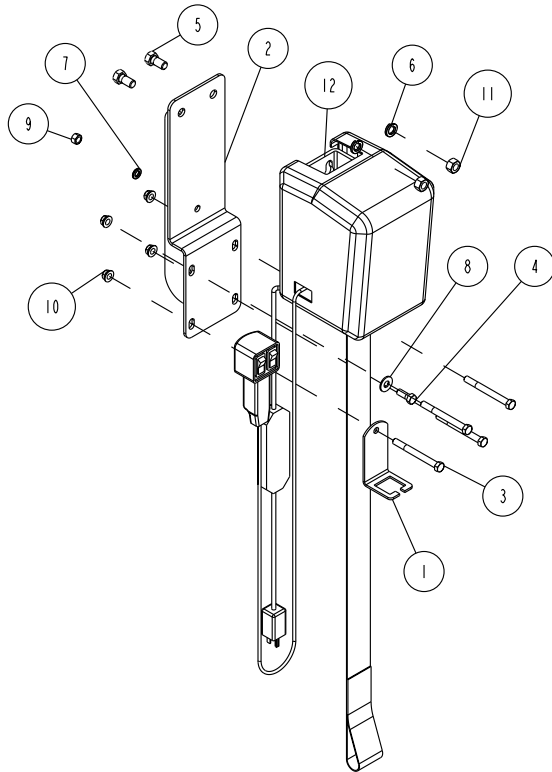

ITEM	PART #	DESCRIPTION	QTY	NOTE
1	67419	PWC ELEC. CONTROL HOLDER	1	
2	68504	ELECTRIC WINCH MTG. BRACKET	1	
3	0110059	HH 3/8-16 X 3 3/4 CS GR5	4	
4	0140040	HH 3/8-16 X 1 CS GR5	1	
5	0140090	HH 1/2-13 X 1 CS GR5	2	
6	1310040	LOCKWASHER 1/2 S/T MED	2	
7	1340030	LOCKWASHER 3/8 S/T MED ULTRASEAL	1	
8	1340095	WASHER USS FLAT 3/8	1	
9	1410109	HEX NUT 3/8-16	1	
10	1440101	HEX LOCKNUT FLANGE 3/8-16 W/T&T	4	
11	1440159	HEX NUT FINISH 1/2-13	2	
12	3110393	WINCH ELEC DLSA9015AC W/108" STRAP	1	

## Replacement Parts

304390\* 84" WINCH STRAP-SS853DSE/  
SS8531DSE

\* DL Replacement Numbers

DWG: SS1053DSE REV: 1.1+

# SS1053DSE / SS10531DSE Parts Drawing

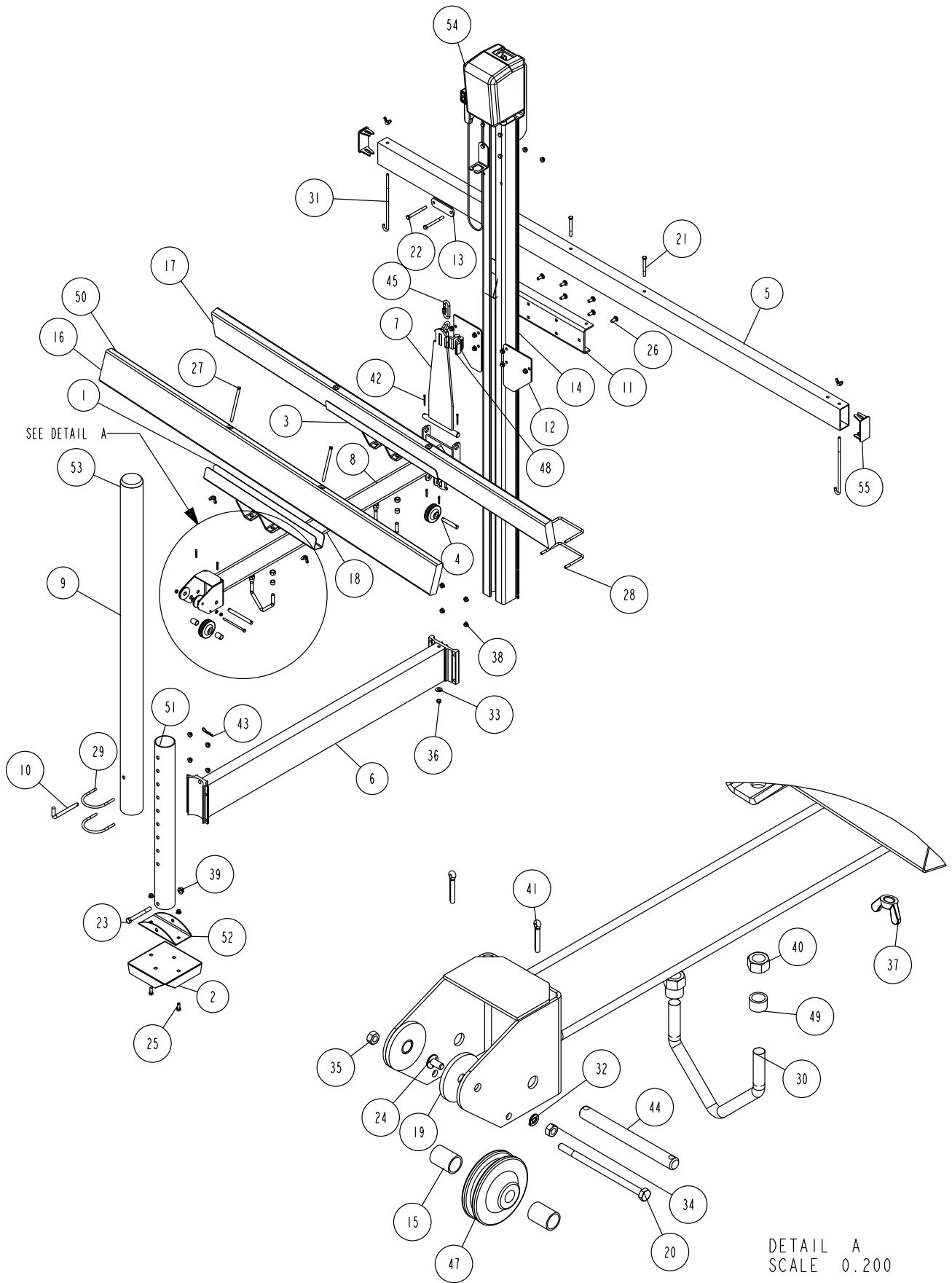

DETAIL A  
SCALE 0.200

# Tools Required

9/16" Socket/Wrench

3/4" Socket/Wrench



1. Bundles as shown.

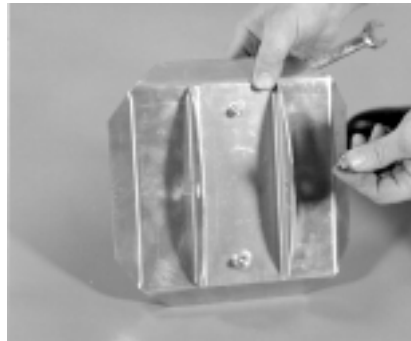

2. Install the aluminum base pad channel clamp to the base pad using two (2) 3/8" X 1" hex bolts and two (2) 3/8" flange lock nuts.



3. Mount the adjustable leg to the base pad channel using a 1/2" X 4-1/2" hex bolt and secure with a 1/2" flange lock nut.

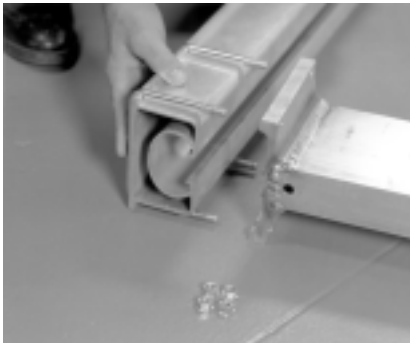

4. Mount the lower frame weldment (Ref.#6) to the winch post extrusion (Ref.#14) using two (2) 3/8" X 5-3/16" X 3-7/8" square u-bolts (Ref.#28) as shown. Secure with 3/8" flange lock nuts.

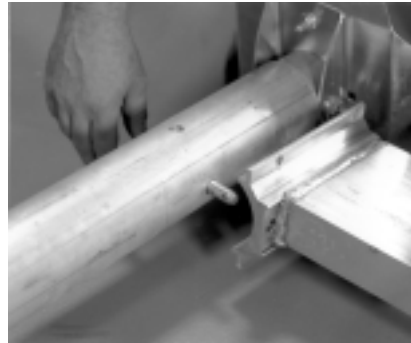

5. Mount the guide post tube (Ref.#9) to the opposite end of the lower frame weldment using a leg adjustment pin (Ref.#10). Secure with a hitch pin clip (Ref.#43).



6. Also mount the guide post tube to the opposite end of the lower frame tube using two (2) 3/8" X 3-7/8" X 3-7/8" SUB's. Secure with 3/8" flange lock nuts.

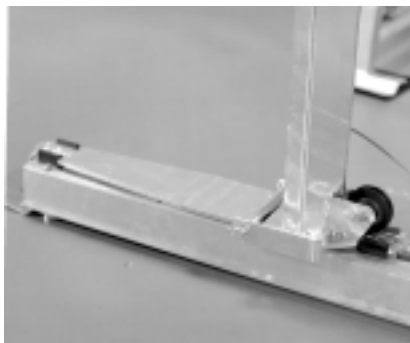

7. Slide the platform assembly into the winch post extrusion (Ref.#14) as shown.



8. Slide the opposite end of the platform assembly over the guide post tube as shown. **Note: Be sure that the cable end is in the notch in the end of the guide post.**



9. Run the threaded end of the cable through the lower frame weldment as shown.



10. Secure the cable end to the under side of the lower frame weldment with a 3/8" flat washer and 3/8" hex nut.



11. Mount the electric winch to the winch mounting plate using two (2) 1/2" X 1" hex bolts in the top two (2) mounting holes and one (1) 3/8" X 1" hex bolt in the single lower mounting hole. Secure with two (2) 1/2" lock washers and two (2) 1/2" hex nuts. Secure the 3/8" X 1" hex bolt with a 3/8" lock washer and a 3/8" hex nut.



12. Mount the electric winch assembly that is attached to the mounting plate to the winch post using four (4) 3/8" X 3-3/4" hex bolts. Slide the electric control holder over the end of the one of the lower 3/8" X 3-3/4" hex bolts on either side of the electric winch. See diagram on page 2. Secure with four (4) 3/8" flange lock nuts. Place the electric controller unit into the electric control holder.



13. Connect the end of the winch strap to the platform weldment assembly as shown.  
**NOTE: The strap must be free of any twisting.**



14. Mount the stop plate (Ref.#13) to the winch post extrusion using two (2) 3/8" X 3-3/4" hex bolts. Secure with 3/8" flange lock nuts.

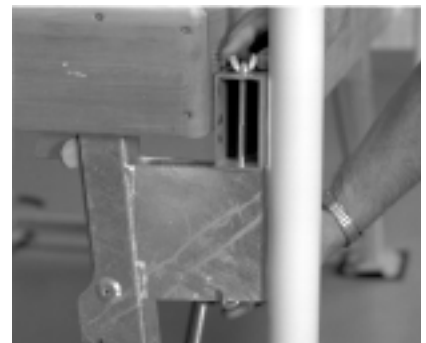

15. Mount the dock mount tube (Ref.#5) between the dock and bumper as shown. Secure the dock mount tube using a 3/8" X 10-1/2" j-hook (Ref.#31) hooking from the bottom of the dock leg universal bracket up as shown. Secure with a 3/8" wing nut.



16. Insert the ShoreLand'r end cap into the ends of the dock mount tubes as shown.



17. Mount one (1) hoist attach plate (Ref.#12) to the winch post mounting channel (Ref.#11) using three (3) 3/8" X 1" carriage bolts (Ref.#26). Secure with 3/8" flange lock nuts.  
**NOTE: The hoist attach plate must be hooked over the lip on the winch post extrusion.** Place the other hoist attach plate onto the opposite side of the winch post extrusion - be sure this plate extends over the lip of the winch post extrusion before tightening.



18. Mount the entire hoist by sliding the winch post mounting channel over the dock mount tube (Ref.#5) and drop two 3/8" X 3-1/4" hex bolts down through holes on winchpost mounting channel to secure the hoist to the dock.



19. Insert the black plastic cap (Ref.#53) into the guide post tube as shown.

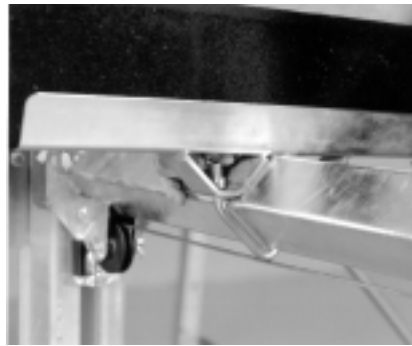

21. Mount the bunk with brackets onto the platform weldment using two (2) 1/2" v-shaped u-bolts (Ref.#30), two (2) spacers (Ref.#49) and two (2) 1/2" hex lock nuts per bunk as shown. **Note: The short end of bunk from galvanized mounting channel goes to the right of the winch handle (as reference - Refer to picture 22 for Right and Left of hoist).** Repeat on other bunks. Bunks should be spaced to fit your watercraft before tightening. Bunks should also be angled toward the center of the platform. **NOTE: To enter the dock hoist from the other end - reverse the bunk assembly.**

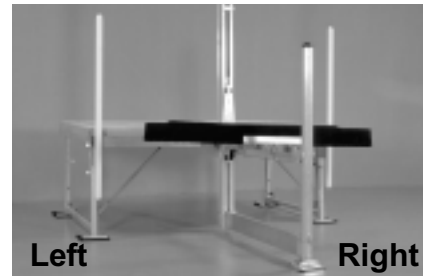

22. SS853DSE shown with assembly being complete.

**Caution:** Before attempting to install and or operate this hoist, we strongly recommend (both for your safety and that of your equipment) that you study and fully understand the proper operating procedures and safety precautions outlined on page 8 of this owner's manual.

**⚠ DANGER**  
**DO NOT** submerge controller in water.  
 Electrical shock may result.

**SAFETY INSTRUCTIONS**



"IN" - Raises hoist  
 "OUT" - Lowers Hoist  
 "RUN" - Energizes winch system

**Removing Boat from Hoist**

1. Standing on dock, lower hoist until PWC is supported by hoist platform but nearly floating free.
2. Board PWC.
3. Once seated, with engine idling in reverse, lower hoist until PWC begins to exit hoist.

**Returning Boat to Hoist**

1. Upon returning, platform will be at proper loading height. Position PWC on hoist.
2. Raise hoist until PWC rests solidly on hoist platform.
3. Exit PWC. Rotate controller back to dock side as you exit.
4. While standing on dock, raise hoist to maximum height.

**IMPORTANT:** Use caution while raising and lowering hoist. Read Owner's Manual before operating hoist.

4811460

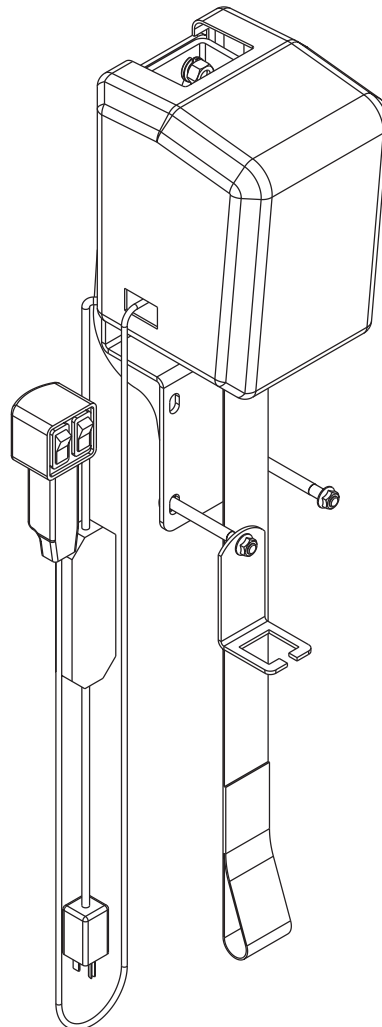

**Electric Drive Winch**

**⚠ DANGER**

Do **NOT** use unit without a ground fault interruptor at the power source. Failure to do so may result in electrical shock.

Installation must be done by a qualified electrician.

4811455

SHOCK HAZARD  
 Use Ground Fault Interrupter

**⚠ DANGER**

**⚠ DANGER**

SHOCK HAZARD  
 Use Ground Fault Interrupter

483017E

# Safety Tips

## “The best insurance policy is safety”

After the hoist installation is complete, it is important to next check and see that the winch mechanism is functioning properly. This is easily accomplished by raising the empty platform about one-fourth the way up and releasing your grasp on the lift handle. If the winch is operating properly, the clutch brake will automatically hold the platform at any position. Perform this same test in the half, three-fourths and full lift positions. Next, repeat this same procedure with your boat on the hoist. If the lift handle begins to freely spin down from any of these test positions, at no time should you attempt to prevent it from doing so. Such action could result in injury to arms and hands. Instead simply let the platform spin down into the water. Doing so will neither damage your hoist nor your watercraft.

If for some reason your winch mechanism does not function as described call your authorized Shore Station dealer. Do not tamper with the winch mechanism.

## SAFETY PRECAUTIONS

### DO NOT OPERATE THIS HOIST WITHOUT FIRST STUDYING THIS OWNER’S MANUAL

1. See to it that you, your family, and anyone else who uses the hoist looks upon the unit not as a toy, but a piece of heavy equipment that deserves your respect and good judgment.
2. Before allowing anyone to operate the unit, be sure they fully understand the proper operating procedure.
3. Do not exceed maximum capacity unit, overloading may cause mechanical failure and serious personal injury.
4. All persons should stand clear and should not be allowed to board your watercraft when it is being raised or lowered.
5. If you choose to remove the winch cover and inspect or work on the winch, be sure the platform is completely lowered.
6. It is a good safety policy to restrict children, as well as adults, from playing on or near the hoist.
7. Service winch annually. **IMPORTANT:** Winch maintenance schedule must be followed to avoid possible failure and injury. See winch owner’s manual for instructions.
8. Check cable for wear or fraying and also stress on cable attaching ends. If this occurs, replace cable immediately.
9. Be sure the hoist is installed level, severe out of level installation may cause hoist hand up and serious personal injury.
10. Do not work on you watercraft or hoist with watercraft on the hoist.
11. Check all sheaves, make sure they are turning and operating properly.
12. Check fasteners on cable ends to be positive they are threaded properly (see setting up instructions).
13. If the winch handle begins to freely spin down for any reason, at no time should you attempt to prevent it from doing so. Such action could result in injury to arms and hands. Instead, simply let the platform spin down into the water. Doing so will neither damage your watercraft or hoist.
14. Never pick up on platform of hoist while trying to move, position, or transport hoist. Doing so may cause serious personal injury.
15. Never stand or walk on hoist platform while in any raised position. Doing so may cause serious personal injury.

## SAFETY MAINTENANCE

It is recommended that your Shore Station hoist be thoroughly inspected at least once each season:

1. Tighten all bolts.
2. Check pulleys and make sure they are all turning freely.
3. Inspect all cables for fraying, wearing or deteriorating. If any signs appear, replace cables.
4. Check frame thoroughly.
5. Check winch as per manufacturer’s specifications.

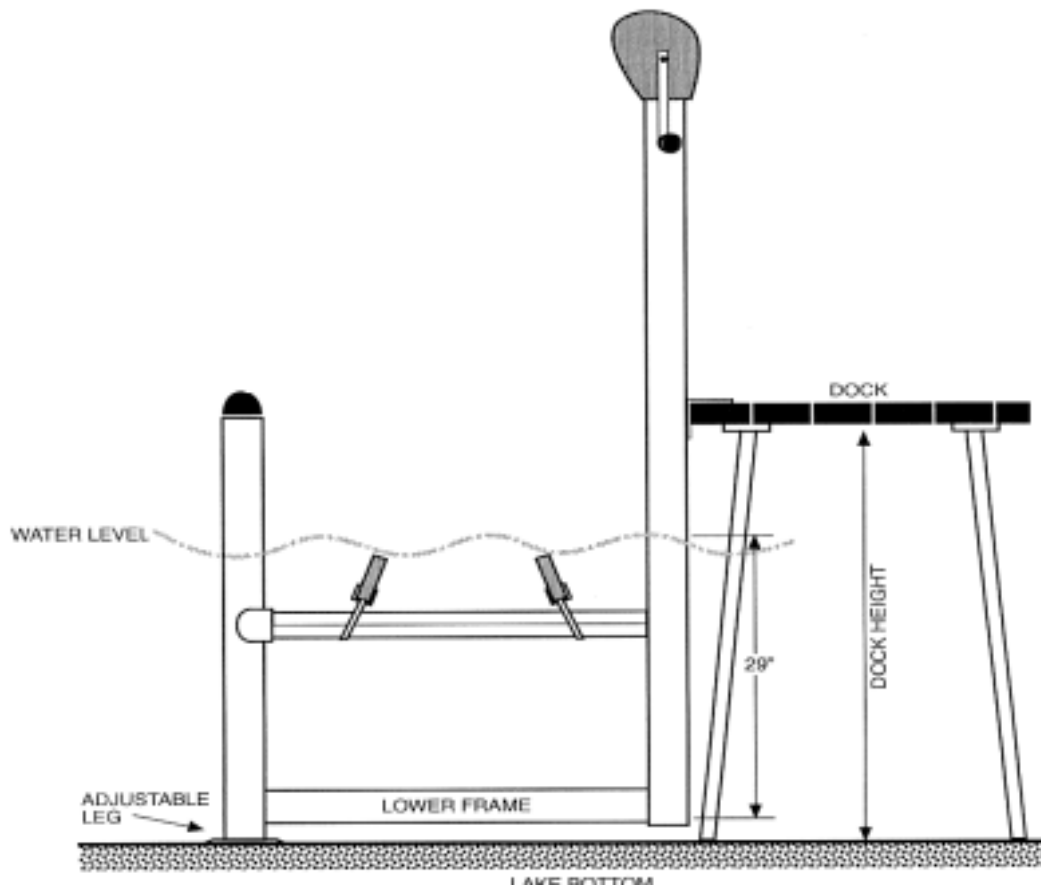

After final assembly, you are now ready for installation. Once the location is determined you need to find the water depth and the dock height.

Using a pole or a 2X4, insert it into the water and locate solid bottom to water level. Mark both the water level and the top of the on the 2X4.

Remove the pole and measure the distance from solid bottom to water level.

You must allow 17" for the lower cross member and bunk height, then add floatation allowance plus the water distance to the top of the dock figure, dock mount tube should be set at this measurement. Subtract this measurement from the lake bottom to the top of the dock measurement to get the leg extension measurement. **NOTE:** Allowances may have to be made for uneven lake bottom in the leg setting measurement.

The distance of dock to water line plus 29" equals position to set the top of the dock mount tube.