

SSN Aluminum Centering Device for the Steel Hoist

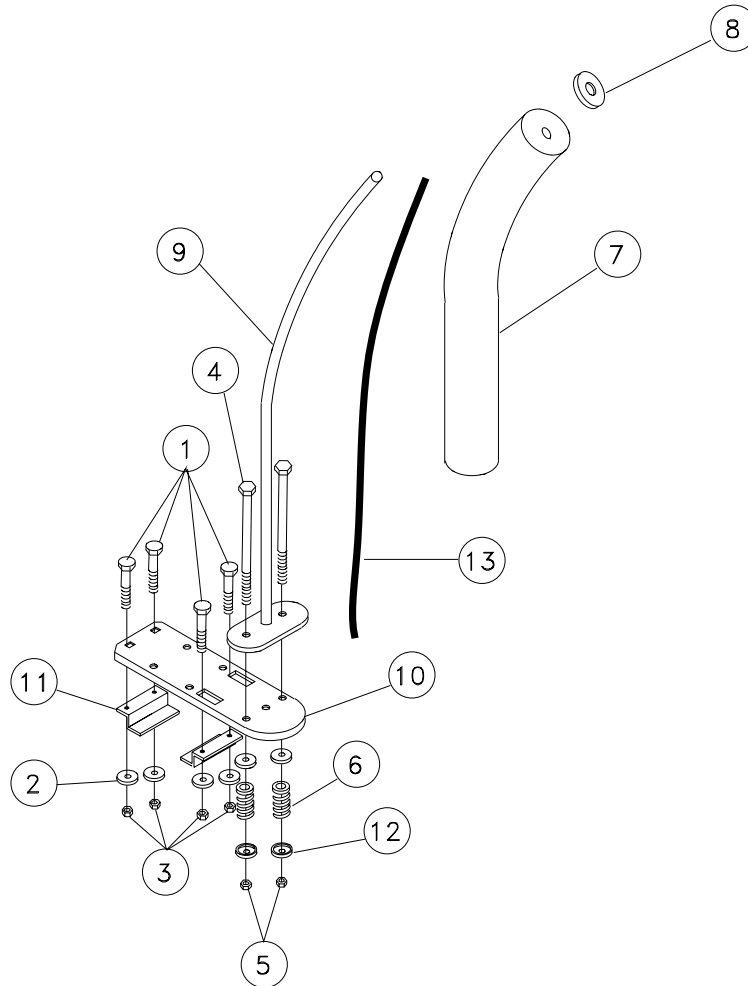

REF#	PART#	DESCRIPTION	QTY
1	0210058	5/16" X 1" CARRIAGE BOLT	16
2	1310085	5/16" USS FLAT WASHER	16
3	1410069	5/16" HEX NUT	16
4	0210135	3/8" X 4-1/2" CARRIAGE BOLT	8
5	1410109	3/8" HEX NUT	8
6	2110501	COMPRESSION SPRING	8
7	3510005	4" POLYETHANLENE LOG - 27" LONG 4	
8	3510012	2" OD X 3/8" ID X 3/16" WASHER	4
9	A148	RIGHT SSN STEM	2
--	A149	LEFT SSN STEM	2
10	A150	5/16" X 4" ALUMINUM BAR SSN MTG . 4	
11	A208	SSN MNTG CLAMP FOR 2" WOOD	8
12	B1325	GALVANIZED CUP WASHER	16
13	SS1121	POLY ROPE - 4'	4

SSN Assembly Instructions

Fasten one (1) SSN mounting clamp in position as shown in the drawing with two (2) 5/16" X 1" carriage bolt, flat washer and 5/16" hex nuts. Do not tighten. Slip the SSN on the "H" platform with the mounting bracket under the "H" platform flange. Place into position and secure the second mounting clamp in the same manner as above. Position the unit on the platform. Tighten all fasteners.

IMPORTANT: Place the centering device so that the top of the stern points out the open end of the hoist and will stay clear of the guide post brace and winch tubes when raising and lowering the platform.